

---

**Alp 4.0 - M4 2008**  
**Euro 3**

**CATALOGO PARTI DI RICAMBIO**  
**CATALOGUE OF SPARE PARTS**  
**CATALOGUE PIECES DE RECHANGE**  
**ERSATZTEILKATALOG**  
**CATALOGO DE PIEZAS DE REPUESTO**



TAV.1 - Carburatore - Carburettor

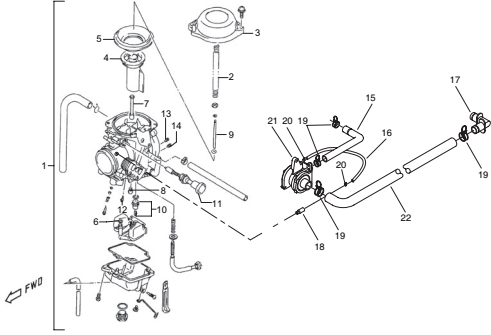

TAV.2 - Testa-cilindro - Cylinder head

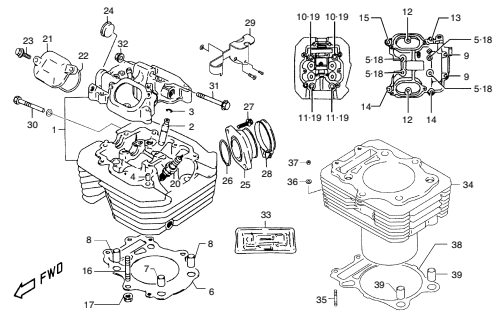

TAV.3 - Basamento - Cylinder base

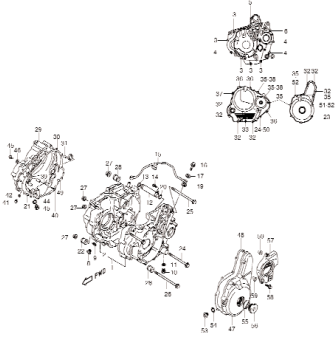

TAV.4 - Albero motore-pistone - Crankshaft-Piston

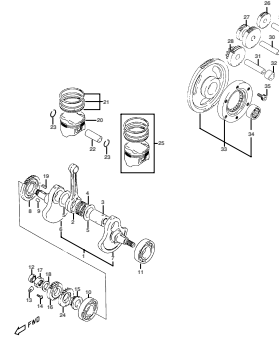

TAV.5 - Albero a camme-valvole - Camshaft-Valves

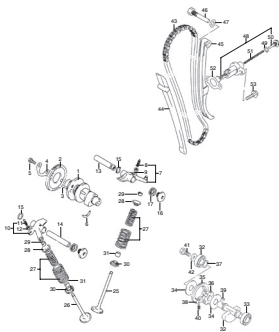

TAV.6 - Frizione - Clutch

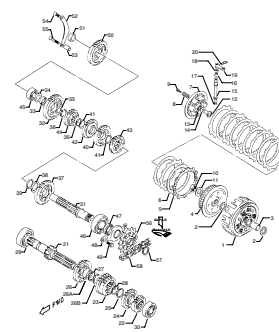

TAV.7 - Pompa olio-volano - Flywheel oil pump

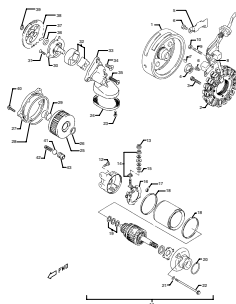

TAV.8 - Cambio velocità - Gear box

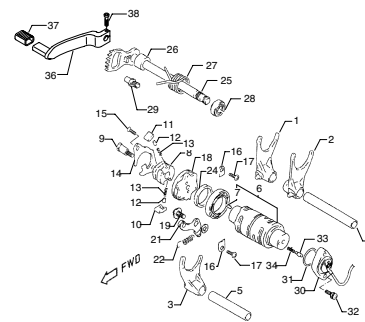

TAV.9 - Filtro aria - Air filter

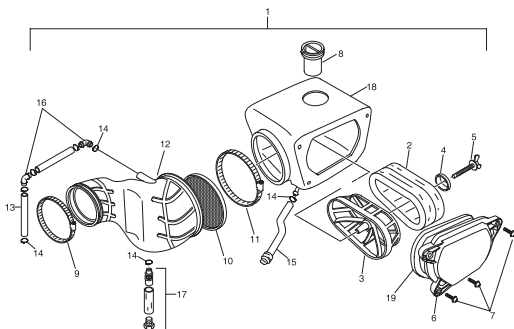

TAV.10 - Marmitta - Silencers

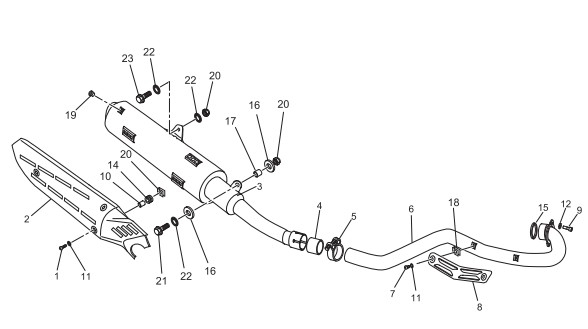

TAV.11/TAV 11a - Fanaleria-dispositivi elettrici - Lights-electric devices (Alp 4.0/M4)

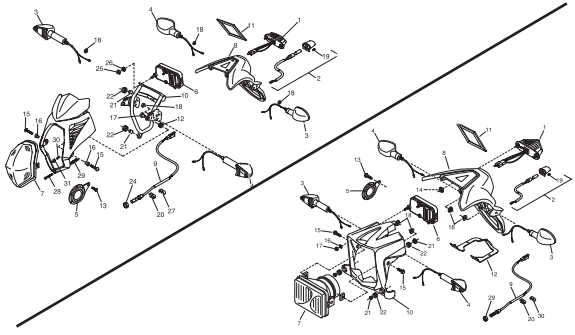

TAV.12 - Telaio-pedane poggiapiedi - Frame-footrests

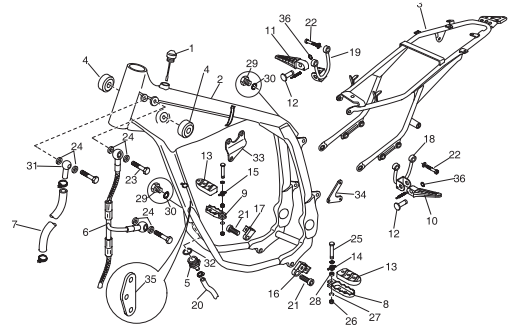

TAV.13 - Forcellone-Sospensione posteriore - Fork-rear suspensions

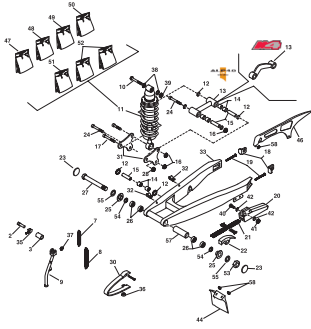

TAV.14/TAV.14a - Gruppo plastiche - Plastic parts group (Alp 4.0/M4)

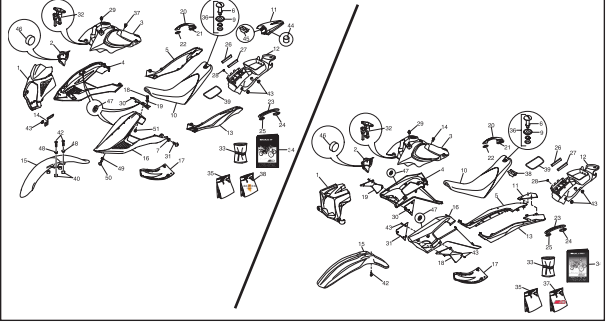

TAV.15/ TAV. 15a- Gruppo ruote - Wheels group M4

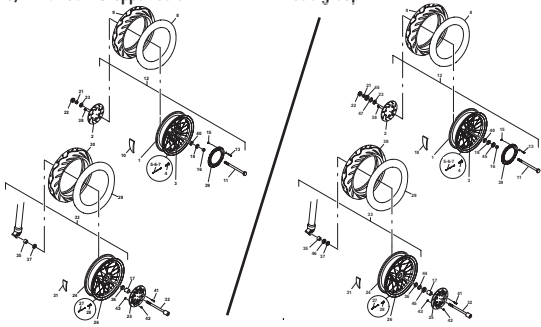

TAV.16 - Gruppo ruote - Wheels group Alp 4.0

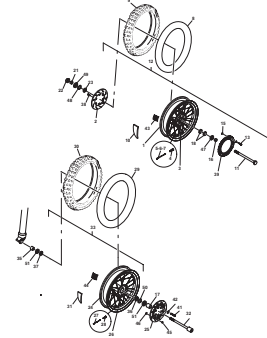

TAV.17 - Sospensione anteriore - Front suspensions

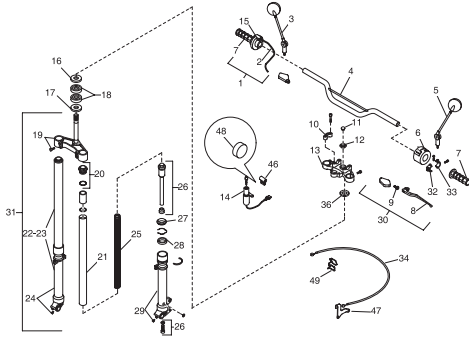

TAV.18 - Impianto frenante - Braking system

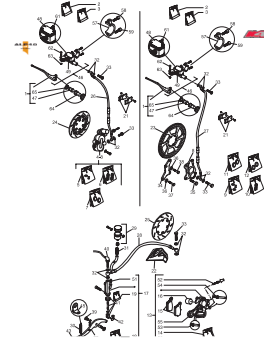

TAV.19 - Impianto elettrico - Electric installation

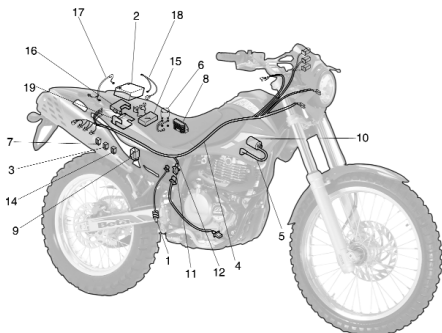

# Tav.1

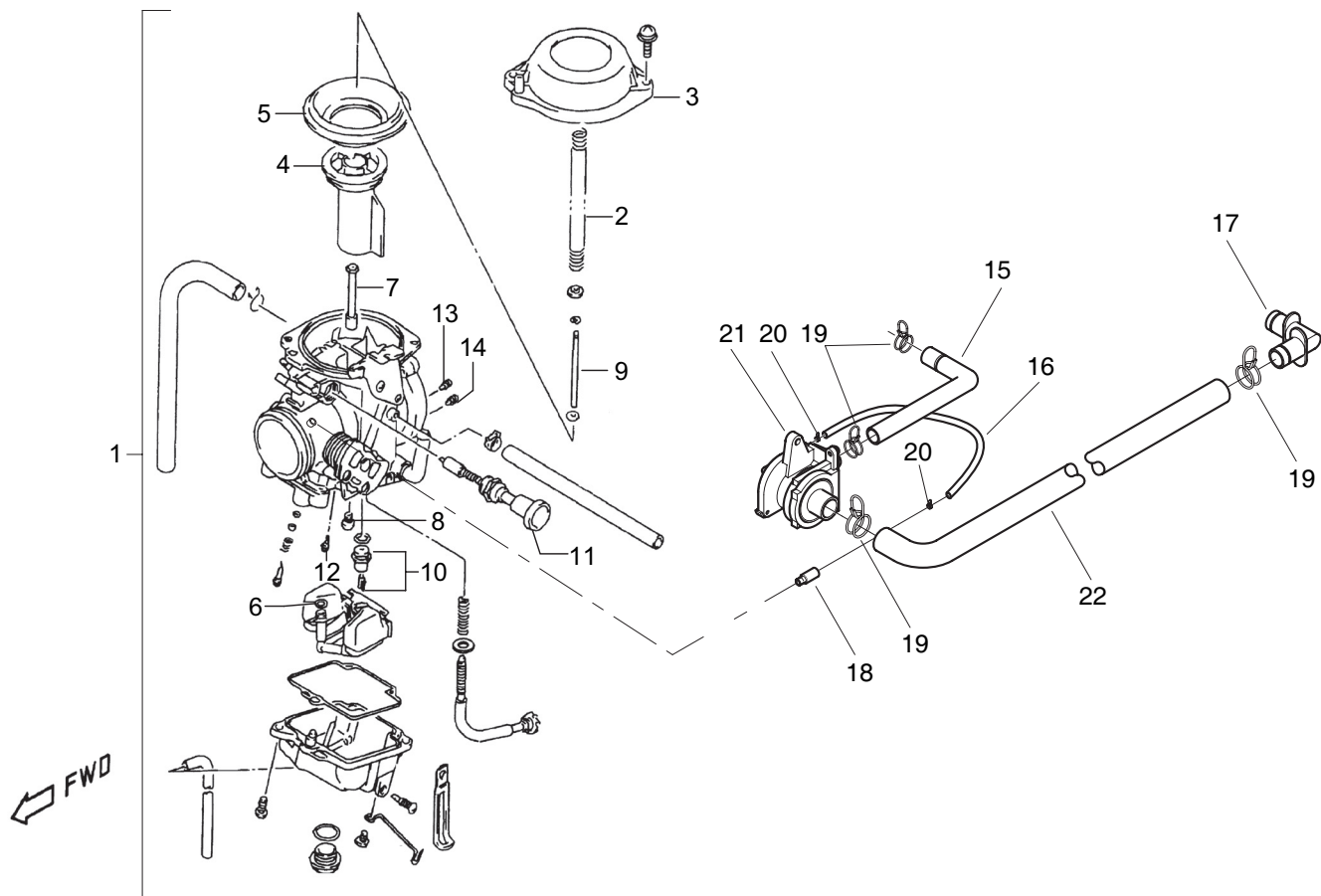

Pos Loc Pos Ps Pos	Numero Number Número Número	Nota Note Note Nota Anm.	Descrizione	Description	Désignation	Beschreibung	Descripcìon
1	1204899 000		Carburatore	Carburettor	Carbureteur	Vergaser	Carburador
2	3533350 000		Molla	Spring	Ressort	Feder	Muelle
3	3533360 000		Coperchio diaframma	Diaphragm cover	Couvercle diaphragme	Membrandeckel	Tapa diafragma
4	3533370 000		Valvola	Valve	Valve	Ventil	Válvula
5	3533380 000		Diaframma	Diaphragm	Diaphragme	Membran	Diafragma
6	3533390 000		Galleggiante	Float	Flotteur	Schwimmer	Flotador
7	3532650 000		Getto spillo	Needle jet	Jet pointeau	Nadeldüse	Aguja surtidor
8	3531790 000		Getto massimo	Main jet	Jet maximal	Hauptdüse	Surtidor de alta
9	3533400 000		Getto spillo	Needle jet	Jet pointeau	Nadeldüse	Aguja surtidor
10	3533410 000		Valvola completa	Complete valve	Valve complète	Ventil komplett	Válvula completa
11	3533420 000		Pomello completo	Complete knob	Poignée complète	Einstellschraube komplett	Botón esférico completo
12	3533430 000		Getto pilota	Pilot jet	Jet pilote	Pilotdüse	Surtidor pilota
13	3532640 000		Getto aria 1,2	Air jet 1.2	Jet air 1,2	Luftdüse 1,2	Surtidor aire 1,2
14	3533440 000		Getto aria 0,6	Air jet 0.6	Jet air 0,6	Luftdüse 0,6	Surtidor aire 0,6
15	29-15851-000		Tubo valvola/scarico	Valve/exhaust pipe	Tuyau soupape/échapp.	Leitung Ventil/Auspuffrohr	Tubo válvula/escape
16	29-15962-000		Tubo 3/8"	Pipe 3/8"	Tuyau 3/8"	Schlauch 3/8"	Tubo 3/8"
17	27-11020-000		Raccordo 90°	Joint.p. 90°	Raccord 90°	Stutzen 90°	Racor 90°
18	27-23502-000		Raccordo valvola/carburatore	Valve/carburettor union	Raccord soupape/carb.	Ventil/Vergaser ansluß	Empalme válvula/carburador
19	10-67440-000		Anello stringitubo	Pipe clamping ring	Anneau serre-tube	Schlauchschelle	Anillo prensatubo
20	10-67450-000		Anello stringitubo	Pipe clamping ring	Anneau serre-tube	Schlauchschelle	Anillo prensatubo
21	31-15030-000		Valvola AIS	Valve AIS	Soupape AIS	Ventil AIS	Válvula AIS
22	29-15852-000		Tubo valvola/filtro	Valve/filter pipe	Tuyau soupape/filtre	Leitung Ventil/Filter	Tubo válvula/filtro



**Beta**  
the play bike

# Tav.2

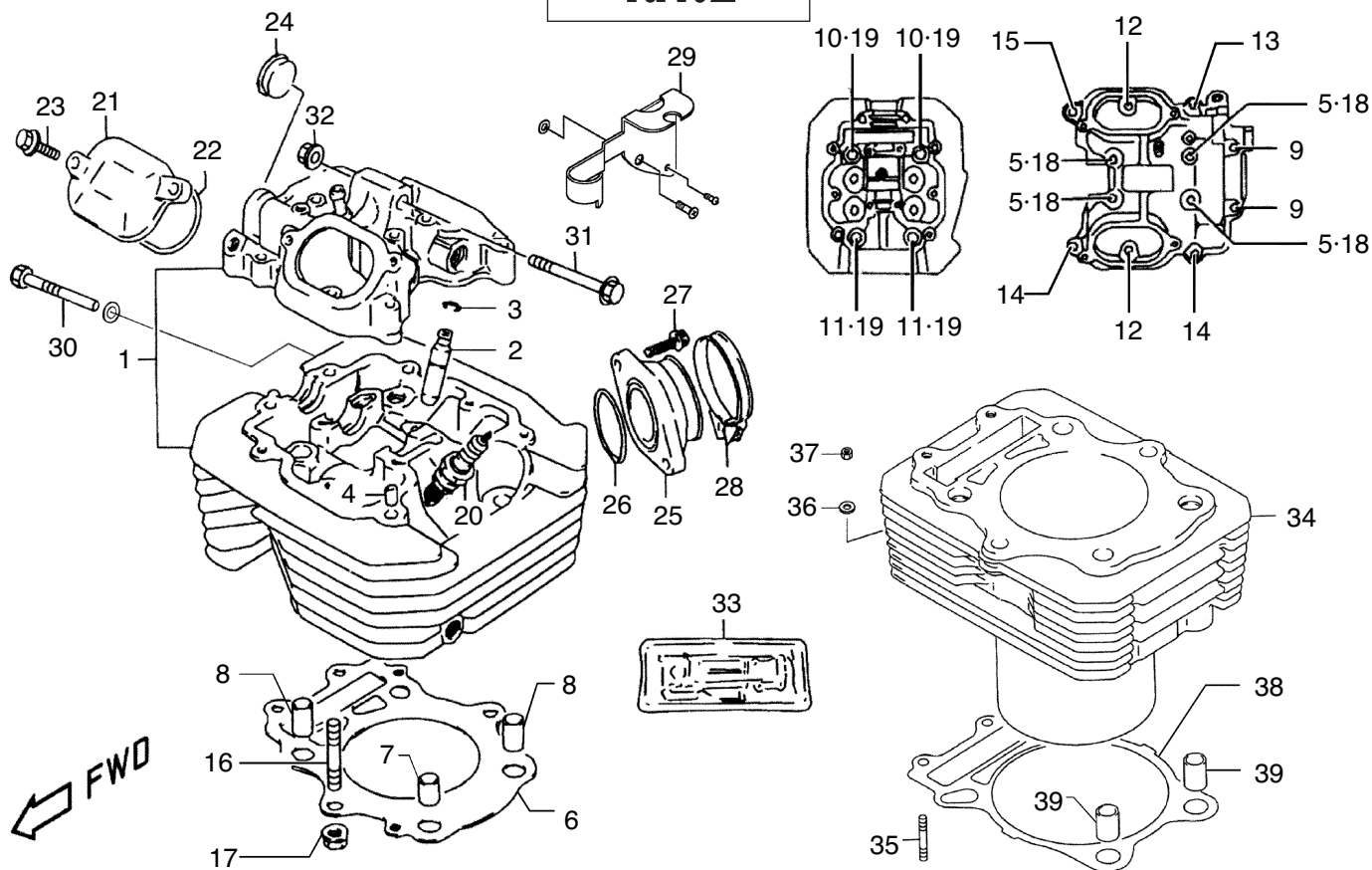

Pos Loc Pos Ps Pos	Numero Number Numéro Número Nummer	Nota Note Note Nota Anm.	Descrizione	Description	Désignation	Beschreibung	Descripción
1	3530010 000		Testa motore 350cc	350 cc engine head	Tête moteur 350 cc	Zylinderkopf 350 cm <sup>3</sup>	Culata motor 350 cc
2	3530020 000		Guida valvole	Valve guide	Glissière valves	Ventilführung	Guía válvulas
3	3510030 000		Seeger guida valvole	Valve guide Seeger	Seeger glissières valves	Seegerring Ventilführung	Anillo de retención guía válvulas
4	3510040 000		Spina	Pin	Goupille	Stift	Pasador
5	3530030 000		Bullone 6,55	6.55 bolt	Boulon 6,55	Schraubbolzen 6,55	Tornillo 6,55
6	3530040 000		Guarnizione cilindro testa	Head cylinder gasket	Head cylinder garniture	Zylinderkopfichtung	Junta cilindro culata
7	3510250 000		Spina I18	I18 pin	Goupille I18	Stift I18	Pasador I18
8	3530050 000		Spina I22	I22 pin	Goupille I22	Stift I22	Pasador I22
9	3530060 000		Bullone 6, 155	6. 155 bolt	Boulon 6, 155	Schraubbolzen 6, 155	Tornillo 6,155
10	3530070 000		Bullone 10, 180	10. 180 bolt	Boulon 10, 180	Schraubbolzen 10, 180	Tornillo 10,180
11	3530080 000		Bullone 10, 155	10. 155 bolt	Boulon 10, 155	Schraubbolzen 10, 155	Tornillo 10,155
12	3510822 000		Bullone	Bolt	Boulon	Schraubbolzen	Tornillo
13	3530090 000		Bullone	Bolt	Boulon	Schraubbolzen	Tornillo
14	3530100 000		Bullone 6,35	6.35 bolt	Boulon 6,35	Schraubbolzen 6,35	Tornillo 6,35
15	3530110 000		Bullone 6,40	6.40 bolt	Boulon 6,40	Schraubbolzen 6,40	Tornillo 6,40
16	3530120 000		Prigioniero	Stud bolt	Prisonnier	Stiftschraube	Espárrago
17	3510982 000		Dado	Nut	Écrou	Mutter	Tuerca
18	3510070 000		Guarnizione 5,8.13.1,2	5.8, 13, 1.2 gasket	Garniture 5,8.13.1,2	Dichtung 5,8.13.1,2	Junta 5.8. 13. 1,2
19	3530130 000		Rondella	Washer	Rondelle	Unterlegscheibe	Arandela
20	3530140 000		Candela (ngk, cr9ek)	Spark plug (ngk, cr9ek)	Bougie (ngk, cr9ek)	Zündkerze (NGK, cr9ek)	Bujía (ngk, cr9ek)
21	3530200 000		Coperchio ispezione	Inspection cover	Couvercle regard	Inspektionsklappe	Tapa de inspección
22	3530210 000		Anello or	O Ring	O Ring	O Ring	Anillo O-Ring
23	3530220 000		Bullone	Bolt	Boulon	Schraubbolzen	Tornillo
24	3530230 000		Tappo testa	Head plug	Bouchon tête	Zylinderkopf-Verschlussdeckel	Tapa culata
25	3530240 000		Bocchettone	Union	Goulotte	Stutzen	Brida de unión
26	3530260 000		Anello or	Ring	O Ring	O-Ring	Anillo O-Ring
27	3530270 000		Vite	Screw	Vis	Schraube	Tornillo
28	3530280 000		Fascetta	Clamp	Collier serrage	Schelle	Abrazadera
29	3530290 000		Staffa supporto trasmissione gas	Gas transmission support bracket	Pièce d'appui transmission gaz	Gaszughalterung	Brida soporte transmisión gas
30	3530300 000		Bullone	Bolt	Boulon	Schraubbolzen	Tornillo
31	3530310 000		Bullone 8,65	8.65 bolt	Boulon 8,65	Schraubbolzen 8,65	Tornillo 8,65
32	3530320 000		Dado	Nut	Écrou	Mutter	Tuerca
33	3530330 000		Guarnizione	Gasket	Garniture	Dichtung	Junta
34	3530340 000		Cilindro motore 350cc	350 cc engine cylinder	Cylindre moteur 350 cc	Motorzylinder 350 cm <sup>3</sup>	Cilindro motor 350 cc
35	3530350 000		Prigioniero	Stud bolt	Prisonnier	Stiftschraube	Espárrago
36	3530360 000		Rondella	Washer	Rondelle	Unterlegscheibe	Arandela
37	3530370 000		Dado	Nut	Écrou	Mutter	Tuerca
38	3530380 000		Guarnizione cilindro	Cylinder gasket	Garniture cylindre	Zylinderdichtung	Junta cilindro
39	3510250 000		Spina	Pin	Goupille	Stift	Pasador

# Tav.3

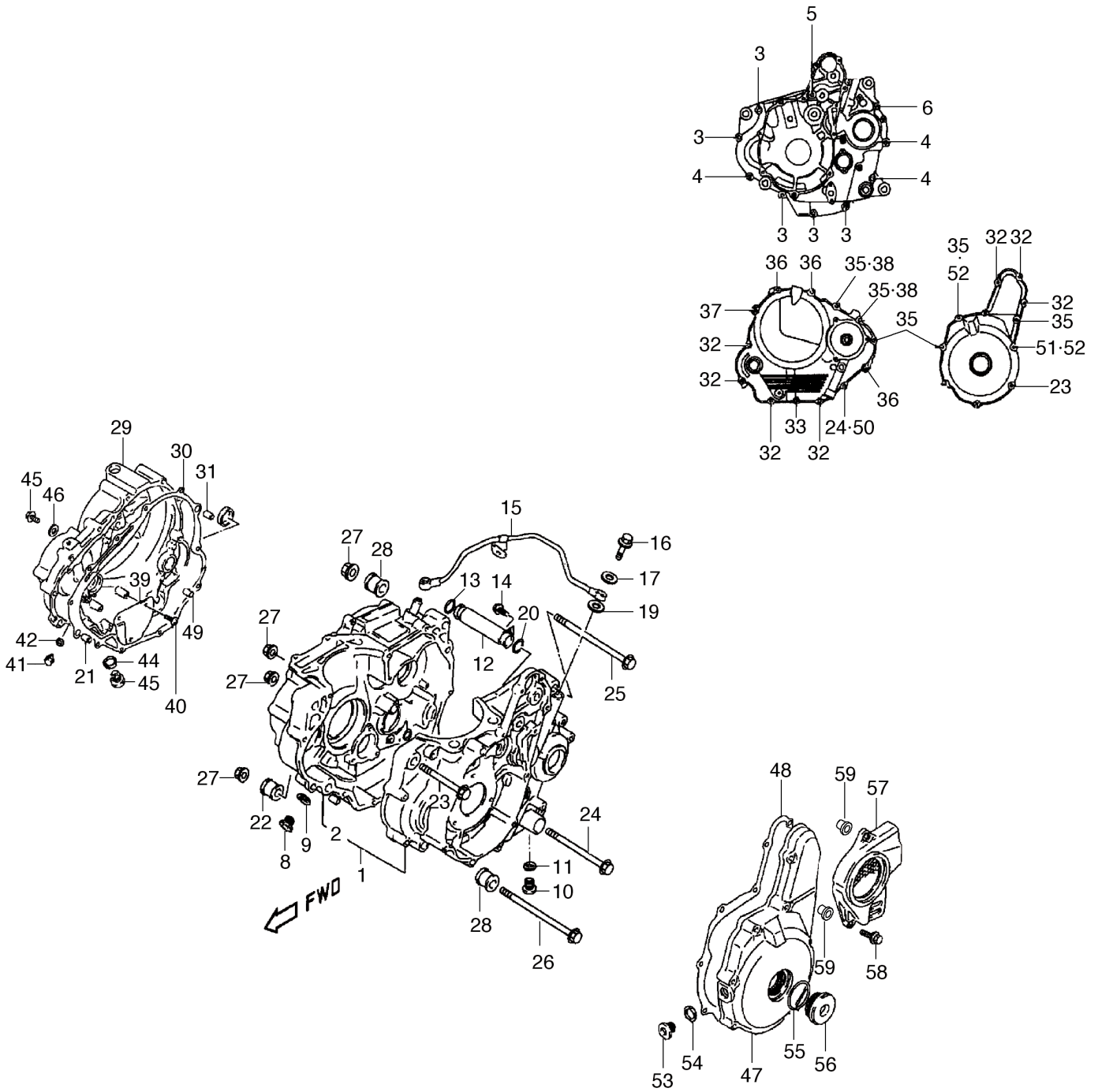

# Tav.3

Pos Loc Pos Ps Pos	Numero Number Número Número Nummer	Nota Note Note Nota Anm.	Descrizione	Description	Désignation	Beschreibung	Descripción
1	3530390 000		Carter motore 350cc	350 cc engine case	Carter moteur 350 cc	Motorgehäuse 350 cm <sup>3</sup>	Cárter motor 350cc
2	3530400 000		Spina	Pin	Goupille	Stift	Pasador
3	3510372 000		Bullone	Bolt	Boulon	Schraubbolzen	Tornillo
4	3530410 000		Bullone	Bolt	Boulon	Schraubbolzen	Tornillo
5	3530370 000		Bullone	Bolt	Boulon	Schraubbolzen	Tornillo
6	3530420 000		Bullone	Bolt	Boulon	Schraubbolzen	Tornillo
8	3530440 000		Tappo olio inserimento	Oil filling plug	Bouchon remplissage huile	Öl-Einfüllverschluss	Tapón introducción aceite
9	3510410 000		Guarnizione	Gasket	Garniture	Dichtung	Junta
10	3530450 000		Tappo olio scarico	Oil drain plug	Bouchon vidange huile	Öl-Ablassschraube	Tapón drenaje aceite
11	3510460 000		Guarnizione	Gasket	Garniture	Dichtung	Junta
12	3530460 000		Condotto olio interno	Inner oil pipeline	Tuyau huile externe	Innere Ölleitung	Conducto aceite interno
13	3530470 000		O ring (d:2.4, id:15.8)	O-Ring (d: 2.4, id: 15.8)	O Ring (diam: 2.4, int: 15.8)	O-Ring (d:2.4, id:15.8)	Anillo O-Ring (d: 2.4, id:15,8)
14	3530480 000		Bullone	Bolt	Boulon	Schraubbolzen	Tornillo
15	3530490 000		Tubo olio esterno	Outer oil pipeline	Tuyau huile interne	Äußere Ölleitung	Tubo aceite externo
16	3530500 000		Bullone tubo olio	Oil pipe bolt	Boulon tuyau huile	Schraubbolzen Ölleitung	Tornillo tubo aceite
17	3510940 000		Guarnizione	Gasket	Garniture	Dichtung	Junta
18	3530430 000		O ring (d:1.9, id:12.6)	O-Ring (d: 1.9, id: 12.6)	O-Ring (diam: 1.9, int: 12.6)	O-Ring (d:1.9, id:12.6)	Anillo O-Ring (d:1.9, id: 12.6)
19	3510940 000		Guarnizione	Gasket	Garniture	Dichtung	Junta
20	3530470 000		O ring (d:2.4, id:15.8)	O-Ring (d: 2.4, id: 15.8)	O-Ring (diam: 2.4, int: 15.8)	O-Ring (d:2.4, id:15.8)	Anillo O-Ring (d:2.4, id:15.8)
21	3530400 000		Spina	Pin	Goupille	Stift	Pasador
22	3530610 000		Distanziale (l:19,85)	Spacer (l: 19.85)	Entretoise (l: 19,85)	Abstandhalter (l:19,85)	Pasador (l:19,85)
23	3530560 000		Bullone (10x85)	Bolt (10x85)	Boulon (10x85)	Schraubbolzen (10x85)	Tornillo (10x85)
24	3530570 000		Bullone (10x100)	Bolt (10x100)	Boulon (10x100)	Schraubbolzen (10x100)	Tornillo (10x100)
25	3530580 000		Bullone (10x115)	Bolt (10x115)	Boulon (10x115)	Schraubbolzen (10x115)	Tornillo (10x115)
26	3530590 000		Bullone (10x143)	Bolt (10x143)	Boulon (10x143)	Schraubbolzen (10x143)	Tornillo (10x143)
27	3530600 000		Dado	Nut	Écrou	Mutter	Tuerca
28	3530610 000		Distanziale (l:19,85)	Spacer (l: 19.85)	Entretoise (l: 19,85)	Abstandhalter (l:19,85)	Pasador (l:19,85)
29	3530620 000		Coperchio frizione	Clutch housing pan	Couvercle embrayage	Kupplungsdeckel	Tapa embrague
30	3530630 000		Guarnizione coperchio frizione	Clutch housing pan gasket	Garniture couvercle embrayage	Kupplungsdeckeldichtung	Junta tapa embrague
31	3530400 000		Spina	Pin	Goupille	Stift	Pasador
32	3530640 000		Bullone	Bolt	Boulon	Schraubbolzen	Tornillo
33	3510371000		Bullone	Bolt	Boulon	Schraubbolzen	Tornillo
34	3530650 000		Bullone	Bolt	Boulon	Schraubbolzen	Tornillo
35	3530660 000		Bullone	Bolt	Boulon	Schraubbolzen	Tornillo
36	3510252 000		Bullone	Bolt	Boulon	Schraubbolzen	Tornillo
37	3530670 000		Bullone	Bolt	Boulon	Schraubbolzen	Tornillo
38	3510370 000		Guarnizione	Gasket	Garniture	Dichtung	Junta
39	3530680 000		Separatore ritorno olio	Oil return separator	Séparateur retour huile	Scheider Ölrückleitung	Separador retorno aceite
40	3530690 000		Vite 5x10	Screw (5x10)	Vis (5x10)	Schraube 5x10	Tornillo 5x10
41	3530700 000		Tappo olio inserimento (6x8)	Oil filling plug (6x8)	Bouchon remplissage huile (6x8)	Öl-Einfüllschraube (6x8)	Tapón introducción aceite (6x8)
42	3530710 000		Guarnizione	Gasket	Garniture	Dichtung	Junta
43	3530720 000		Tappo olio inserimento	Oil filling plug	Bouchon remplissage huile	Öl-Einfüllschraube	Tapón aceite introducción
44	3530730 000		Guarnizione	Gasket	Garniture	Dichtung	Junta
45	3530740 000		Tappo olio inserimento	Oil filling plug	Bouchon remplissage huile	Öl-Einfüllschraube	Tapón aceite introducción
46	3510370 000		Guarnizione	Gasket	Garniture	Dichtung	Junta
47	3530750 000		Coperchio volano	Flywheel cover	Couvercle volant	Lichtmaschinendeckel	Tapa volante magnético
48	3530760 000		Guarnizione coperchio volano	Flywheel cover gasket	Garniture couvercle volant	Dichtung Lichtmaschinendeckel	Empaque tapa volante
49	3530400 000		Spina	Pin	Goupille	Stift	Pasador
50	3530770 000		Bullone	Bolt	Boulon	Schraubbolzen	Tornillo
51	3510372 000		Bullone	Bolt	Boulon	Schraubbolzen	Tornillo
52	3510370 000		Guarnizione	Gasket	Garniture	Dichtung	Junta
53	3530440 000		Tappo, t.d.c.	Plug, top-dead-center	Bouchon, pt.m.sup.	Verschluss, t.d.c.	Tapón, t.d.c.
54	3510410 000		Guarnizione	Gasket	Garniture	Dichtung	Junta
55	3530780 000		Tappo coperchio volano	Flywheel cover plug	Bouchon couvercle volant	Verschluss Lichtmaschinendeckel	Tapón tapa volante magnético
56	3530790 000		O ring (d:3.1, id:32,7)	O-Ring (d: 3.1, id: 32.7)	O Ring (diam: 3.1, int: 32,7)	O-Ring (d:3.1, id:32,7)	Anillo O-Ring (d:3.1, id:32,7)
57	1273076 157		Coperchio pignone catena	Chain sprocket cover	Carter pignon de chaîne	Abdeckung Kettenritzel	Tapa piñón cadena
58	1149070 000		Bullone 6 x 20	Bolt 6 x 20	Boulon 6 x 20	Schraubbolzen 6 x 20	Tornillo 6 x 20
59	1362000 000		Distanziale	Spacer	Entretoise	Abstandhalter	Pasador

# Tav.4

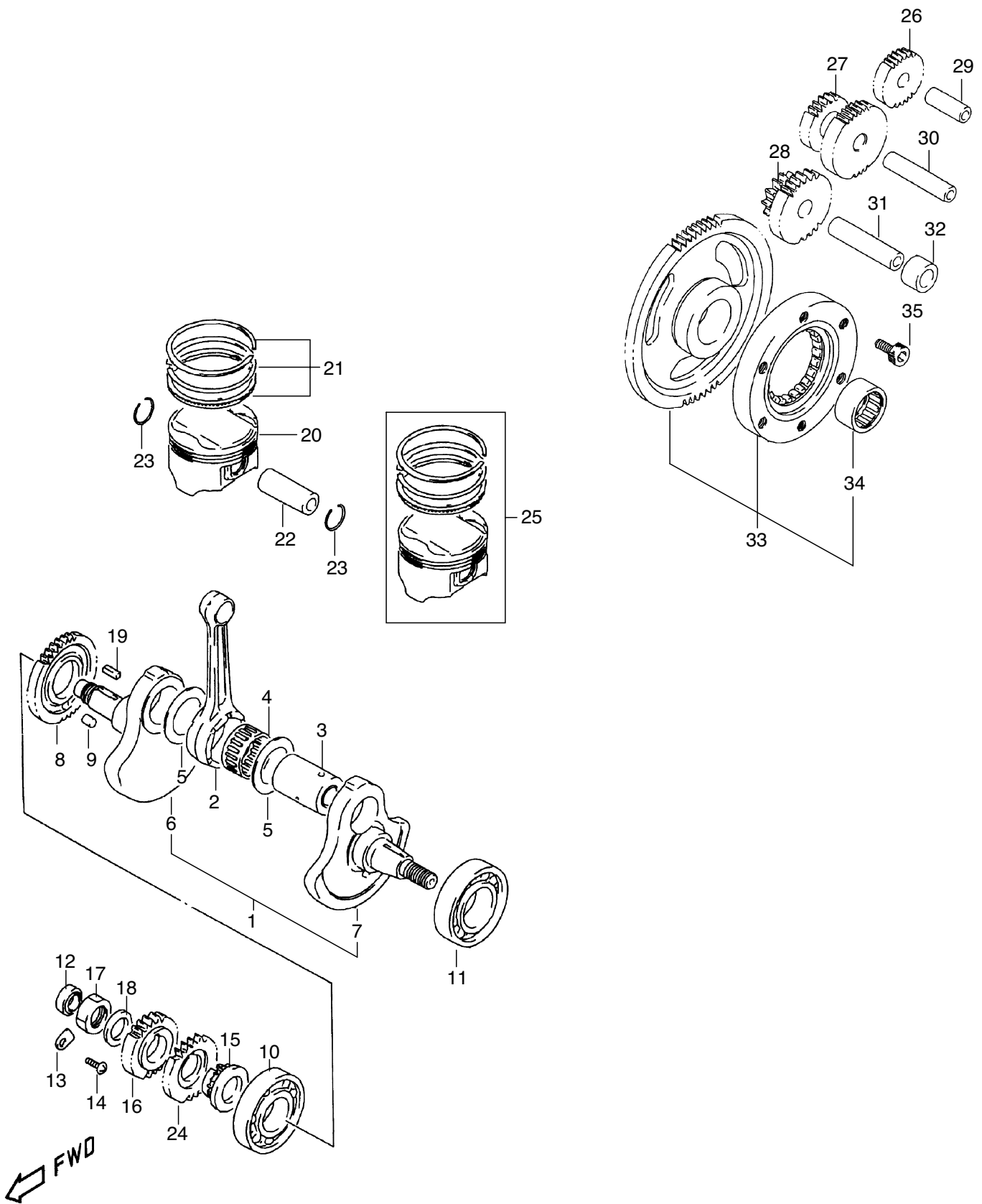



# Tav.4

Pos Loc Pos Ps Pos	Numero Number Numéro Número Nummer	Nota Note Note Nota Anm.	Descrizione	Description	Désignation	Beschreibung	Descripción
1	3530940 000		Albero motore completo	Complete driving shaft	Arbre moteur complet	Kurbelwelle komplett	Cigüeñal completo
2	3530950 000		Biella	Connecting rod	Bielle	Pleuel	Biela
3	3530960 000		Spina	Pin	Goupille	Stift	Pasador
4	3530970 000		Cuscinetto 834x43x22)	Bearing (834x43x22)	Palier (834x43x22)	Lager (834x43x22)	Rodamiento (34x43x22)
5	3530980 000		Rondella	Washer	Rondelle	Unterlegscheibe	Arandela
6	3530990 000		Albero (contrappeso) destro	Right (counterweight) shaft	Arbre (contrepoids) droit	Welle (Ausgleichsgewicht) rechts	Cigüeñal (contrapeso) derecho
7	3531000 000		Albero (contrappeso) sinistro	Left (counterweight) shaft	Arbre (contrepoids) gauche	Welle (Ausgleichsgewicht) links	Cigüeñal (contrapeso) izquierdo
8	3531010 000		Ingranaggio bilanciamento trasmissione	Transmission balance gear	Engrenage d'équilibrage transmission	AntriebsAusgleichszahnrad	Engranaje balanceo transmisión
9	3531020 000		Spina	Pin	Goupille	Stift	Pasador
10	3531030 000		Cuscinetto destro (30x72x19)	Right bearing (30x72x19)	Palier droit (30x72x19)	Lager rechts (30x72x19)	Cojinete derecho (30x72x19)
11	3531040 000		Cuscinetto sinistro (35x72x17)	Left bearing (35x72x17)	Palier gauche (35x72x17)	Lager links (35x72x17)	Cojinete izquierdo (35x72x17)
12	3531050 000		Anello paraolio destro	Right oil seal unit	Anneau parehuile droit	Öldichtring rechts	Retén de aceite derecho
13	3531060 000		Piastina destra	Right plate	Plaquette droite	Blech rechts	Placa derecha
14	3531070 000		Vite	Screw	Vis	Schraube	Tornillo
15	3531080 000		Corona camma trasmissione a catena	Chain drive cam ring gear	Couronne came transmis. par chaîne	Zahnkranz kettengetriebene Nocke	Corona cama transmisión cadena
16	3531090 000		Ingranaggio trasmissione primaria nt:20	Primary drive gear (nt: 20)	Engrenage transmission primaire (nb. dents.: 20)	Zahnrad Hauptantrieb nt:20	Engranaje transmis. primaria nt:20
17	3531100 000		Dado	Nut	Écrou	Mutter	Tuerca
18	3531110 000		Rondella di fissaggio	Lock washer	Rondelle de fixation	BefestigungsUnterlegscheibe	Arandela de fijación
19	3531120 000		Chiavetta ingranaggio	Gear key	Clavette engrenage	Zahnradkeil	Chaveta engranaje
20	3531130 000		Pistone	Piston	Piston	Kolben	Pistón
21	3531140 000		Segmenti pistone	Piston segments	Segments piston	Kolbenringe	Aros del pistón
22	3531150 000		Spina pistone	Piston pin	Goupille piston	Kolbenbolzen	Pasador pistón
23	3531160 000		Anello ferma spinotto	Gudgeon locking ring	Anneau de blocage axe piston	Sicherungsring Kolbenbolzen	Clip fijación bulón
24	3531170 000		Ingranaggio pompa olio (nt:22)	Oil pump gear (nt: 22)	Engrenage pompe huile (nb. dents: 22)	Ölpumpenzahnrad (nt:22)	Engranaje bomba de aceite (nt:22)
25-1	3531180 000		Pistone completo motore 350cc nt:0,5	350 cc engine piston (nt: 0,5)	Piston complet moteur 350 cc (nb. dents: 0,5)	Kolben komplett für Motor 350 cm³ nt:0,5	Pistón completo motor 350cc nt:0,5
25-2	3531190 000		Pistone completo motore 350cc nt:1,0	350 cc engine piston (nt: 1,0)	Piston complet moteur 350 cc (nb. dents: 1,0)	Kolben komplett für Motor 350 cm³ nt:1,0	Pistón completo motor 350cc nt:1,0
26	3533460 000		Ingranaggio avviamento ozioso No.1	Start idling gear No. 1	Engrenage démarrage lent No. 1	Anlasserzahnrad Nr.1	Piñón de arranque eje libre N. 1
27	3533470 000		Ingranaggio avviamento ozioso No.2	Start idling gear No. 2	Engrenage démarrage lent No. 2	Anlasserzahnrad Nr.2	Piñón de arranque eje libre N. 2
28	3533480 000		Ingranaggio avviamento ozioso No.3	Start idling gear No. 3	Engrenage démarrage lent No. 3	Anlasserzahnrad Nr.3	Piñón de arranque eje libre N. 3
29	3532510 000		Perno (10x32)	Pivot (10x32)	Pivot (10x32)	Welle (10x32)	Perno (10x32)
30	3532500 000		Perno (10x55,5)	Pivot (10x55,5)	Pivot (10x55,5)	Welle (10x55,5)	Perno (10x55,5)
31	3532520 000		Perno (12x55,5)	Pivot (12x55,5)	Pivot (12x55,5)	Welle (12x55,5)	Perno(12x55,5)
32	3533490 000		Distanziale (12,2x20x13)	Spacer (12.2x20x13)	Entretoise (12,2x20x13)	Abstandhalter (12,2x20x13)	Pasador (12,2x20x13)
33	3533500 000		Serie frizione avviamento	Start clutch	Série embrayage démarreur	Serie Anlasserkupplung	Juego embrague de arranque
34	3532580 000		Cuscinetto (27x32x18)	Bearing (27x32x18)	Palier (27x32x18)	Lager (27x32x18)	Cojinete (27x32x18)
35	3520691 000		Bullone	Bolt	Boulon	Schraubbolzen	Tornillo

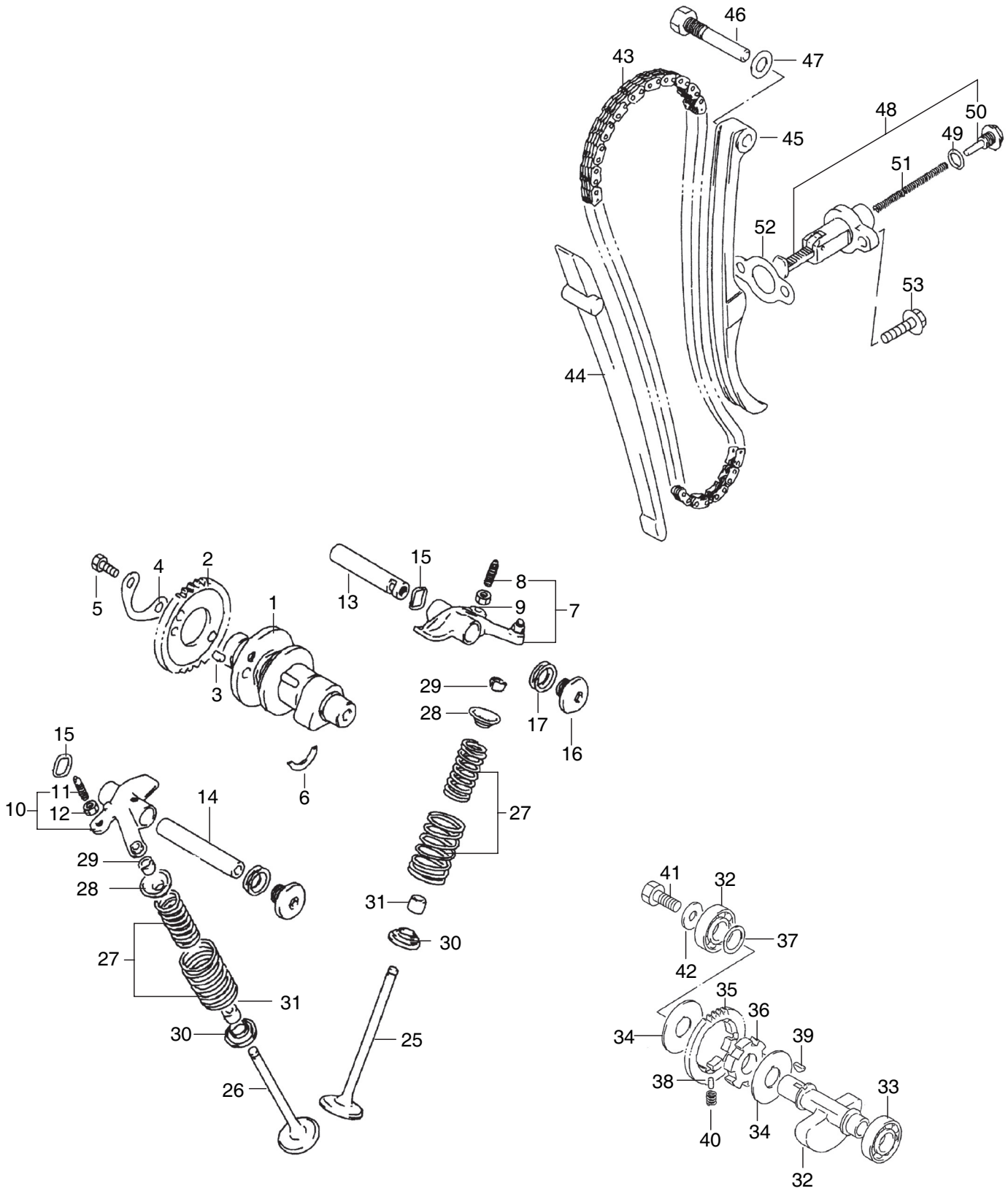

# Tav.5

Pos Loc Ps Pos	Numero Number Numéro Número Nummer	Nota Note Note Nota Anm.	Descrizione	Description	Désignation	Beschreibung	Descripció
1	3531210 000		Asta camma	Cam rod	Tige came	Nockenwelle	Asta cama
2	3531450 000		Corona (nt:34)	Ring gear (nt: 34)	Couronne (nb. dents: 34)	Zahnkranz (nt:34)	Corona (nt:34)
3	3510760 000		Spina	Pin	Goupille	Stift	Pasador
4	3531240 000		Rondella	Washer	Rondelle	Unterlegscheibe	Arandela
5	3510771 000		Bullone (6x10.5)	Bolt (6x10.5)	Boulon (6x10.5)	Schraubbolzen (6x10.5)	Tornillo (6x10.5)
6	3510780 000		O-ring	O-Ring	O-ring	O-Ring	Anillo O-Ring
7	3531250 000		Valvola aspirazione completa	Complete suction valve	Valve aspiration complète	Einlassventil komplett	Válvula admisión completa
8	3531260 000		Vite	Screw	Vis	Schraube	Tornillo
9	3531270 000		Dado	Nut	Écrou	Mutter	Tuerca
10	3531280 000		Valvola scarico completa	Complete exhaust valve	Valve échappement complète	Auslassventil komplett	Válvula escape completa
11	3531260 000		Vite	Screw	Vis	Schraube	Tornillo
12	3531270 000		Dado	Nut	Écrou	Mutter	Tuerca
13	3531290 000		Albero completo interno	Complete inner shaft	Arbre complet interne	Komplette inner Welle	Eje interno completo
14	3531300 000		Albero completo esterno	Complete outer shaft	Arbre complet externe	Komplette äußere Welle	Eje externo completo
15	3531310 000		Rondella	Washer	Rondelle	Unterlegscheibe	Arandela
16	3530440 000		Tappo albero	Shaft plug	Bouchon arbre	Wellenverschluss	Tapón eje
17	3510410 000		Guarnizione	Gasket	Garniture	Dichtung	Junta
25	3531380 000		Valvola aspirazione	Suction valve	Valve aspiration	Einlassventil	Válvula admisión
26	3531390 000		Valvola scarico	Exhaust valve	Valve échappement	Auslassventil	Válvula escape
27	3531400 000		Molle valvole (serie)	Valve springs	Ressorts valves (série)	Ventilfedern (Bausatz)	Muelles válvulas (juego)
28	3531410 000		Molla ritenuta	Lock spring	Ressort retenue	Rückhaltefeder	Muelle de retención
29	3531420 000		Chiavetta valvola	Valve key	Clavette valve	Ventilkeil	Chaveta válvula
30	3531430 000		Sede molla	Spring seat	Hébergement ressort	Federteller	Asiento muelle
31	3531440 000		Anello paraolio (5x10x8,7)	Oil seal unit (5x10x8.7)	Anneau pare-huile (5x10x8,7)	Öldichtring (5x10x8,7)	Retén de aceite (5x10x8,7)
32	3530830 000		Albero di bilanciamento	Balance shaft	Arbre d'équilibrage	Ausgleichswelle	Eje de balanceo
33	3530840 000		Cuscinetto	Bearing	Palier	Lager	Rodamiento
34	3530850 000		Rondella ingranaggio	Gear washer	Rondelle engrenage	Zahnrad-Unterlegscheibe	Arandela engranaje
35	3530860 000		Ingranaggio esterno	Outer gear	Engrenage externe	Äußeres Zahnrad	Engranaje externo
36	3530870 000		Ingranaggio interno	Inner gear	Engrenage interne	Inneres Zahnrad	Engranaje interno
37	3530890 000		Rondella ingranaggio	Gear washer	Rondelle engrenage	Zahnrad-Unterlegscheibe	Arandela engranaje
38	3530900 000		Spina	Pin	Goupille	Stift	Pasador
39	3530910 000		Chiavetta	Key	Clavette	Keil	Chaveta
40	3530920 000		Molla	Spring	Ressort	Feder	Muelle
41	3530930 000		Bullone	Bolt	Boulon	Schraubbolzen	Perno
42	3530941 000		Rondella	Washer	Rondelle	Unterlegscheibe	Arandela
43	3531460 000		Catena distribuzione	Timing chain	Chaîne de distribution	Ventilsteuerkette	Cadena distribución
44	3531470 000		Guida catena distribuzione	Timing chain guide	Glissière chaîne de distribution	Kettenführung Ventilsteuerkette	Guía cadena distribución
45	3531480 000		Tendicatena distribuzione	Timing chain tightener	Tendeur chaîne de distribution	Kettenspanner Ventilsteuerkette	Tensor cadena distribución
46	3510930 000		Bullone	Bolt	Boulon	Schraubbolzen	Perno
47	3510940 000		Rondella	Washer	Rondelle	Unterlegscheibe	Arandela
48	3531490 000		Regolatore tendicatena	Chain tightener adjuster	Régleur tendeur de chaîne	Einstellvorrichtung Kettenspanner	Regulador tensor cadena
49	3520990 000		Anello or	O-Ring	O-Ring	O-Ring	Anillo O-Ring
50	3531500 000		Perno	Pivot	Pivot	Zapfen	Perno
51	3531510 000		Molla	Spring	Ressort	Feder	Muelle
52	3521000 000		Guarnizione regolatore tendicatena	Chain tightener adjuster gasket	Garniture réglleur tendeur de chaîne	Dichtung Einstellvorrichtung Kettenspanner	Junta regulador tensor cadena
53	3530270 000		Bullone	Bolt	Boulon	Schraubbolzen	Perno

# Tav.6

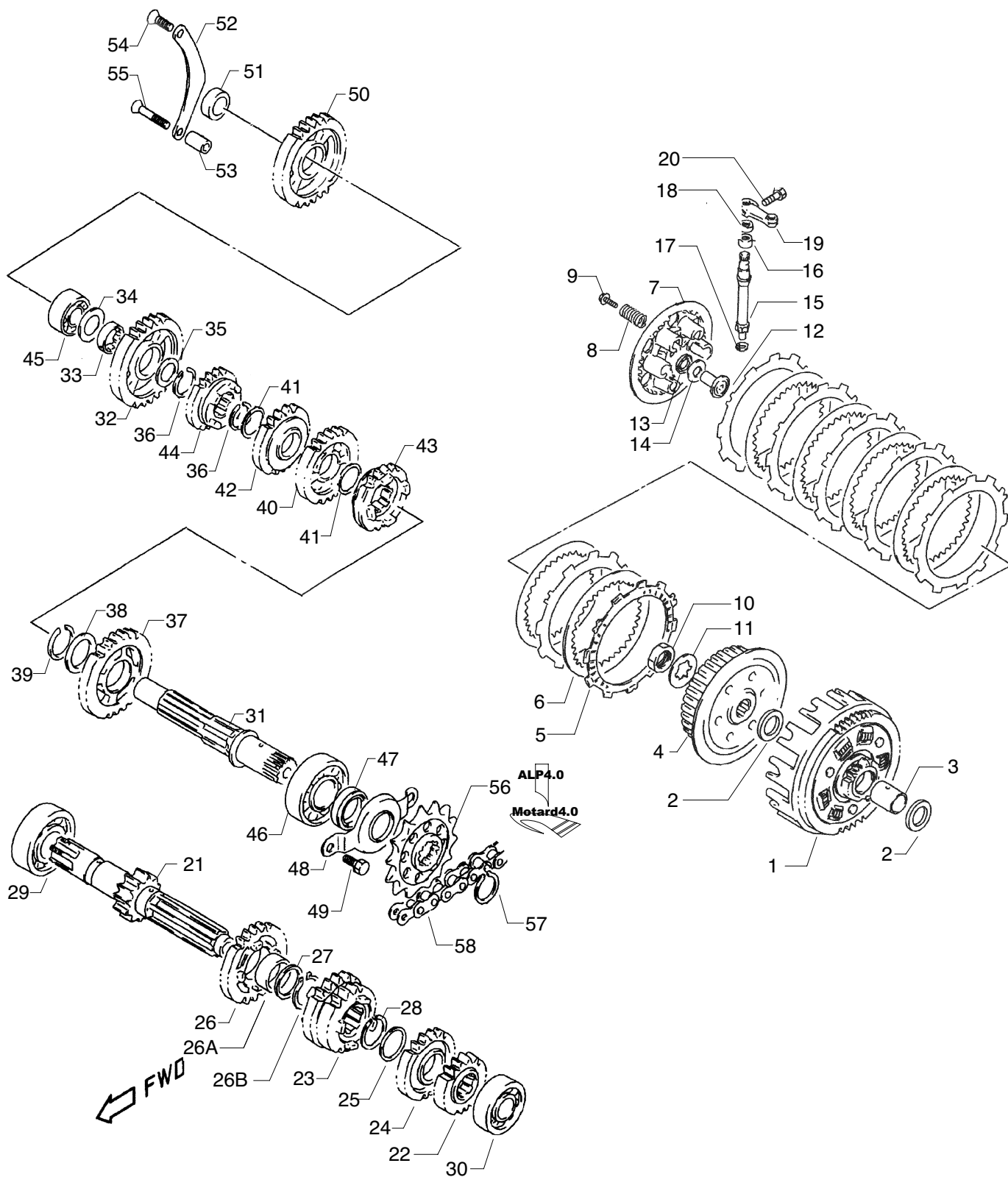

# Tav.6

Pos Loc Pos Ps Pos	Numero Number Numéro Número Nummer	Nota Note Nota Nota Anm.	Descrizione	Description	Désignation	Beschreibung	Descripción
1	3532240 000		Ingranaggio compl.trasmis.prim.	Complete primary drive gear	Engrenage complet transmis. primaire	Komplettes Hauptantriebszahnrad	Engranaje compl. transmis. primaria
2	3532250 000		Rondella	Washer	Rondelle	Unterlegscheibe	Arandela
3	3532260 000		Distanziale (20x25x29)	Spacer (20x25x29)	Entretoise (20x25x29)	Abstandhalter (20x25x29)	Pasador (20x25x29)
4	3532270 000		Coperchio fissaggio camma	Cam fastening cover	Couvercle fixation came	Nocken-Befestigungsdeckel	Tapa fijación cama
5	3532280 000		Disco frizione (T:2,8)	Clutch plate (T: 2.8)	Disque embrayage (T: 2,8)	Kupplungsscheibe (T:2,8)	Disco embrague (T:2,8)
6	3532290 000		Disco frizione (T:1,5)	Clutch plate (T: 1.5)	Disque embrayage (T: 1,5)	Kupplungsscheibe (T:1,5)	Disco embrague (T:1,5)
7	3532300 000		Disco pressione frizione	Clutch pressure plate	Disque pression embrayage	Kupplungs-Druckscheibe	Disco presión embrague
8	3532310 000		Molla	Spring	Ressort	Feder	Muelle
9	3532330 000		Bullone (5x16)	Bolt (5x16)	Boulon (5x16)	Schraubbolzen (5x16)	Perno (5x16)
10	3532340 000		Dado 20 MM	Nut (20 mm)	Écrou (20 mm)	Mutter 20 MM	Tuerca 20 MM
11	3532350 000		Rondella	Washer	Rondelle	Unterlegscheibe	Arandela
12	3532360 000		Perno bloccaggio	Check pin	Goujon de blocage	Befestigungszapfen	Perno fijación
13	3532370 000		Protezione cuscinetto	Bearing guard	Protection palier	Lagerabdeckung	Protección cojinete
14	3532380 000		Rondella fissaggio frizione	Clutch fastening washer	Rondelle fixation embrayage	Unterlegscheibe Kupplungsbefestigung	Arandela fijación embrague
15	3532390 000		Pignone (NT:12) Frizione	Clutch pinion (NT: 12)	Pignon embrayage (nb. dents: 12)	Ritzel (NT:12) Kupplung	Piñón (NT:12) Embrague
16	3532400 000		Cuscinetto 12x16x10	Bearing (12x16x10)	Palier (12x16x10)	Lager 12x16x10	Rodamiento 12x16x10
17	3532410 000		Rondella	Washer	Rondelle	Unterlegscheibe	Arandela
18	3532420 000		Paraolio 10x17x5	Oil seal unit (10x17x5)	Pare-huile (10x17x5)	Öldichtring 10x17x5	Retén de aceite 10x17x5
19	2170172 000		Levetta frizione	Clutch lever	Lévrier embrayage	Kupplungshebel	Leva embrague
20	3532440 000		Bullone	Bolt	Boulon	Schraubbolzen	Perno
21	3532680 000		Albero contagiri (NT:12)	Revolution counter shaft (NT: 12)	Arbre comptage tours (nb. dents: 12)	Welle Drehzahlmesser (NT:12)	Eje cuentavueltas (NT:12)
22	3532860 000		Ingranaggio,2ND (NT:15)	2nd gear (NT: 15)	2 <sup>ème</sup> engrenage (nb. dents: 15)	Zahnrad, 2.Gang (NT:15)	Engranaje, 2º (NT:15)
23	3532710 000		Ingranaggio,3RD 4TH(NT:18/18)	3rd 4th gear (NT: 18/18)	3 <sup>ème</sup> 4 <sup>ème</sup> engrenage (nb. dents:18/18)	Zahnrad, 3.Gang 4.Gang(NT:18/18)	Engranaje, 3º 4º (NT:18/18)
24	3532720 000		Ingranaggio,5TH (NT:21)	5th gear (NT: 21)	5 <sup>ème</sup> engrenage (nb. dents: 21)	Zahnrad, 5.Gang (NT:21)	Engranaje, 5º (NT:21)
25	3532870 000		Rondella (22x26x1.0)	Washer (22x26x1.0)	Rondelle (22x26x1.0)	Unterlegscheibe (22x26x1.0)	Arandela (22x26x1.0)
26	3532730 000		Ingranaggio,6TH (NT:23)	6th gear (NT: 23)	6 <sup>ème</sup> engrenage (nb. dents: 23)	Zahnrad, 6.Gang (NT:23)	Engranaje, 6º (NT:23)
26A	3532880 000		Boccola	Bush	Douille	Buchse	Buje
26B	3532890 000		Seeger	Seeger	Seeger	Seegerring	Seeger
27	3532900 000		Rondella (22x30x1.0)	Washer (22x30x1.0)	Rondelle (22x30x1.0)	Unterlegscheibe (22x30x1.0)	Arandela (22x30x1.0)
28	3521630 000		Seeger	Seeger	Seeger	Seeger	Seeger
29	3532560 000		Cuscinetto (20x52x15)	Bearing (20x52x15)	Palier (20x52x15)	Lager (20x52x15)	Rodamiento (20x52x15)
30	3532910 000		Cuscinetto (17x40x12)	Bearing (17x40x12)	Palier (17x40x12)	Lager (17x40x12)	Rodamiento (17x40x12)
31	3532690 000		Albero	Shaft	Arbre	Welle	Eje
32	3532740 000		Ingranaggio,1ST (NT:29)	1st gear (NT: 29)	1er engrenage (nb. dents: 29)	Zahnrad,1ST (NT:29)	Engranaje, 1º (NT:29)
33	3532920 000		Boccola	Bush	Douille	Buchse	Bujes
34	3532930 000		Rondella SX	Left washer	Rondelle gauche	Unterlegscheibe SX	Arandela IZQ.
35	3532940 000		Rondella DX	Right washer	Rondelle droite	Unterlegscheibe DX	Arandela DER.
36	3521630 000		Seeger	Seeger	Seeger	Seeger	Seeger
37	3532750 000		Ingranaggio,2ND (NT:26)	2nd gear (NT: 26)	2ème engrenage (nb. dents: 26)	Zahnrad,2.Gang (NT:26)	Engranaje 2º (NT:26)
38	3532950 000		Rondella DX	Right washer	Rondelle droite	Unterlegscheibe DX	Arandela DER.
39	3532960 000		Seeger	Seeger	Seeger	Seeger	Seeger
40	3532760 000		Ingranaggio,3RD (NT:24)	3rd gear (NT: 24)	3ème engrenage (nb. dents: 24)	Zahnrad,3.Gang (NT:24)	Engranaje 3º (NT:24)
41	3532970 000		Rondella	Washer	Rondelle	Unterlegscheibe	Arandela
42	3532770 000		Ingranaggio,4HT (NT:20)	4th gear (NT: 20)	4ème engrenage (nb. dents: 20)	Zahnrad, 4.Gang (NT:20)	Engranaje 4º (NT:20)
43	3532780 000		Ingranaggio,5HT (NT:20)	5th gear (NT: 20)	5ème engrenage (nb. dents: 20)	Zahnrad, 5.Gang (NT:20)	Engranaje 5º (NT:20)
44	3532790 000		Ingranaggio,6HT (NT:19)	6th gear (NT: 19)	6ème engrenage (nb. dents: 19)	Zahnrad, 6.Gang (NT:19)	Engranaje, 6º (NT:19)
45	3532590 000		Cuscinetto 17x40x17.5	Bearing (17x40x17.5)	Palier (17x40x17.5)	Lager 17x40x17.5	Rodamiento 17x40x17,5
46	3532570 000		Cuscinetto 22x56x16	Bearing (22x56x16)	Palier (22x56x16)	Lager 22x56x16	Rodamiento 22x56x16
47	3532610 000		Sigillo olio guida albero	Shaft guide oil seal	Scellement huile glissière arbre	Öldichtung Wellenführung	Sellado aceite guía eje
48	3532980 000		Piastrina sigillo olio	Oil seal plate	Plaque scellement huile	Öldichtungsblech	Placa sellado aceite
49	3532990 000		Bullone	Bolt	Boulon	Schraubbolzen	Perno
50	3533000 000		Ingran. ozioso messa in moto a ped.	Pedal start idling gear	Engrenage lent mise en marche à pédale	Kickstarter-Zahnrad	Engran. libre puesta en marcha con pedal
51	3533010 000		Boccola	Bush	Douille	Buchse	Buje
52	3533020 000		Fermo messa in moto a ped.	Pedal start lock	Arrêt mise en marche à pédale	Sicherungsring Kickstarter	Fij. puesta en marcha con pedal
53	3533030 000		Distanziale (6,5x12x21)	Spacer (6,5x12x21)	Entretoise (6,5x12x21)	Abstandhalter (6,5x12x21)	Pasador 6,5x12x21)
54	3532100 000		Vite	Screw	Vis	Schraube	Tornillo
55	3533040 000		Vite	Screw	Vis	Schraube	Tornillo
56	2564076 000	Alp 4.0	Pignone catena Z. 15	Z. 15 chain pinion	Pignon chaîne Z. 15	Kettenritzel Z. 15	Piñón cadena Z. 15
56	2564077 000	M4	Pignone catena Z. 15	Z. 15 chain pinion	Pignon chaîne Z. 15	Kettenritzel Z. 15	Piñón cadena Z. 15
57	3533050 000		Seeger	Seeger	Seeger	Seegerring	Seeger
58	1207287 000	Alp 4.0	Catena 5/8 1/4 P. 112	5/8 1/4 P. 112 chain	Chaîne 5/8 1/4 P. 112	Kette 5/8 1/4 P. 112	Cadena 5/8 1/4 P. 112
58	1207286 000	M4	Catena 5/8 1/4 P. 110	5/8 1/4 P. 110 chain	Chaîne 5/8 1/4 P. 110	Kette 5/8 1/4 P. 110	Cadena 5/8 1/4 P. 110

# Tav.7

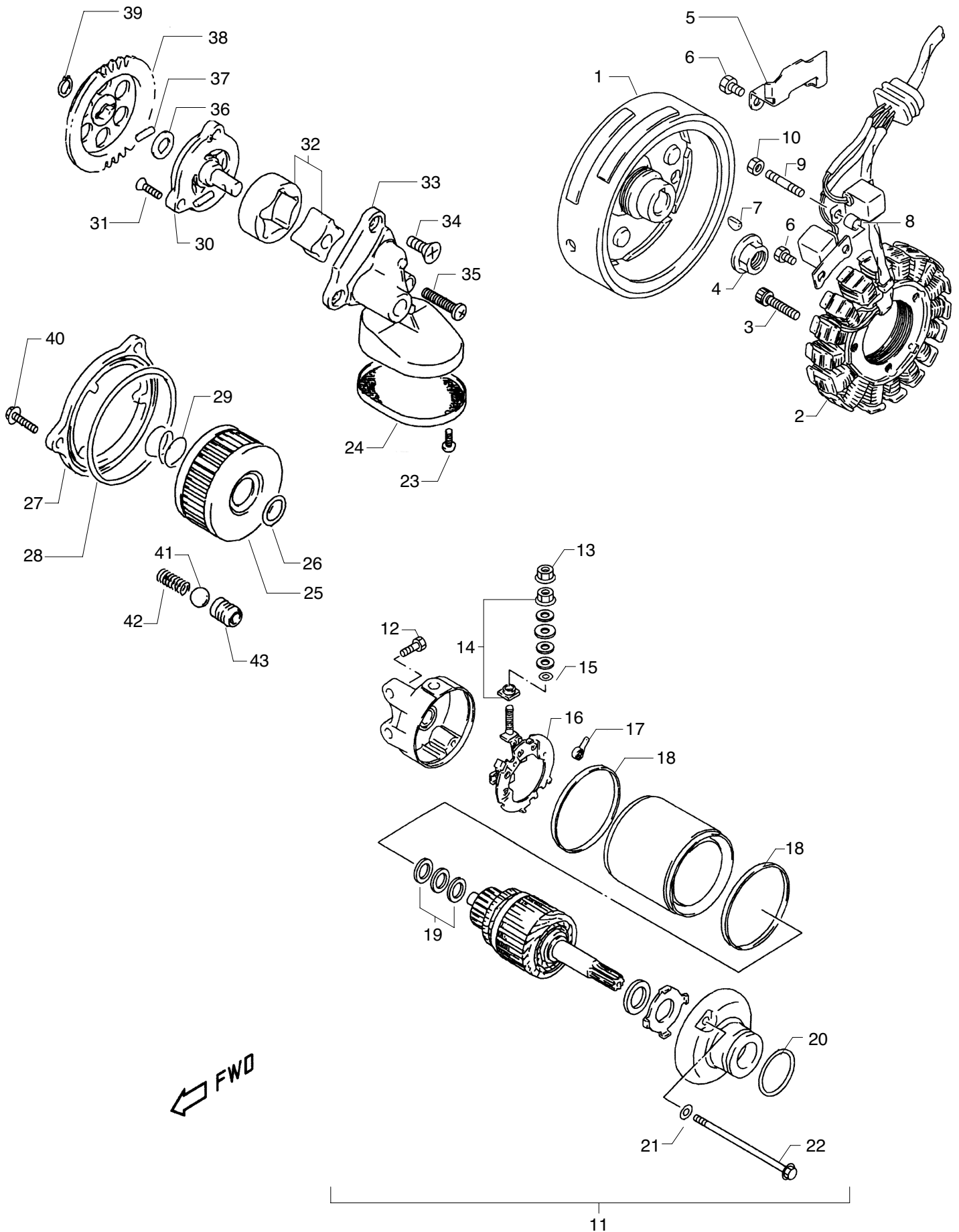

# Tav.7

Pos Loc Ps Pos	Numero Number Numéro Número Nummer	Nota Note Note Nota Anm.	Descrizione	Description	Désignation	Beschreibung	Descripción
1	3533520 000		Rotore	Rotor	Rotor	Rotore	Rotor
2	3533510 000		Statore completo	Complete stator	Stator complet	Stator komplett	Estator completo
3	3533580 000		Bullone 5x10	Bolt (5x10)	Boulon (5x10)	Schraubbolzen 5x10	Perno 5x10
4	3533590 000		Dado	Nut	Écrou	Mutter	Tuerca
5	3533530 000		Piastrina supporto	Support plate	Plaque d'appui	Befestigungsblech	Placa soporte
6	3533540 000		Bullone 5x10	Bolt (5x10)	Boulon (5x10)	Schraubbolzen 5x10	Perno 5x10
7	3533600 000		Chiavetta	Key	Clavette	Keil	Chaveta
8	3533550 000		Distanziale (5,5x9,5x6,5)	Spacer (5.5x9.5x6.5)	Entretoise (5,5x9,5x6,5)	Abstandhalter (5,5x9,5x6,5)	Pasador (5,5x9,5x6,5)
9	3533560 000		Prigioniero	Stud bolt	Prisonnier	Stiftschraube	Espárrago
10	3533570 000		Dado	Nut	Écrou	Mutter	Tuerca
11	3533610 000		Motorino avviamento completo	Complete starter	Démarrreur complet	Anlassermotor komplett	Motor de arranque
12	3533710 000		Bullone	Bolt	Boulon	Schraubbolzen	Perno
13	3533700 000		Dado	Nut	Écrou	Mutter	Tuerca
14	3533620 000		Serie spazzola esterna	Outer brush	Série brosse externe	Bausatz äußere Bürsten	Juego de escobillas externas
15	3533650 000		Anello OR	O-Ring	O Ring	O-Ring	Anillo O-Ring
16	3533630 000		Serie spazzola interna	Inner brush	Série brosse interne	Bausatz innere Bürsten	Juego de escobillas internas
17	3533640 000		Molla spazzola	Brush spring	Brosse ressort	Bürstenfeder	Muelle escobilla
18	3533660 000		Anello OR	O-Ring	O Ring	O-Ring	Anillo O-Ring
19	3533670 000		Serie rondelle motorino avviamento	Starter washers	Série rondelles démarreur	Bausatz Unterlegscheiben Anlassermotor	Juego de arand. motor de arranque
20	3533680 000		Anello OR	O-Ring	O Ring	O-Ring	Anillo O-Ring
21	3512410 000		Anello OR (D:3, ID:24,5)	O-Ring (D: 3, ID: 24.5)	O Ring (Diam: 3, Int.: 24,5)	O-Ring (D:3, ID:24,5)	Anillo O-Ring (D:3, ID:24,5)
22	3533690 000		Serie completa bulloni	Bolts	Série compète boulons	Kompletter Schraubbolzen-Bausatz	Juego completo de pernos
23	3532160 000		Vite	Screw	Vis	Schraube	Tornillo
24	3532150 000		Filtro olio	Oil filter	Filtre huile	Ölfiter	Filtro aceite
25	3532170 000		Filtro motore olio	Oil engine filter	Filtre huile moteur	Motorölfiter	Filtro motor aceite
26	3530470 000		Anello or (d:2.4, id:15.8)	O-Ring (d: 2.4, id: 15.8)	O Ring (diam: 2,4, int: 15.8)	O-Ring (d:2.4, id:15.8)	Anillo O-Ring (d:2.4, id:15.8)
27	3532180 000		Coperchio filtro olio	Oil filter cover	Couvercle filtre huile	Ölfiterdeckel	Tapa filtro aceite
28	3532190 000		Anello or (d:2.4, id:73)	O-Ring (d: 2,4 id: 73)	O Ring (diam: 2,4 int: 73)	O-Ring (d:2.4, id:73)	Anillo O-Ring (d:2.4, id:73)
29	3532200 000		Molla	Spring	Ressort	Feder	Muelle
30	3532050 000		Pompa motorino olio	Oil starter pump	Pompe huile démarreur	Motorölpumpe	Bomba motor aceite
31	3532100 000		Vite	Screw	Vis	Schraube	Tornillo
32	3532110 000		Rotore completo pompa olio	Oil pump rotor	Rotor complet pompe huile	Ölpumpenrotor komplett	Rotor completo bomba aceite
33r	3532120 000		Coperchio pompa olio	Oil pump cover	Couvercle pompe huile	Ölpumpendeckel	Tapa bomba aceite
34	3532140 000		Vite	Screw	Vis	Schraube	Tornillo
35	3532130 000		Vite	Screw	Vis	Schraube	Tornillo
36	3532080 000		Rondella	Washer	Rondelle	Unterlegscheibe	Arandela
37	3532070 000		Spina	Pin	Goupille	Stift	Pasador
38	3532060 000		Ingranaggio guida	Guide gear	Glissière engrenage	Führungszahnrad	Engranaje guía
39	3532090 000		Seeger	Seeger	Seeger	Seeger	Seeger
40	3522690 000		Bullone	Bolt	Boulon	Schraubbolzen	Perno
41	3532220 000		Sfera	Ball	Bille	Kugel	Esfera
42	3532210 000		Molla	Spring	Ressort	Feder	Muelle
43	3532230 000		Sede valvola di controllo olio	Oil check valve seat	Hébergement valve de contrôle huile	Ölkontrollventilsitz	Asiento válvula control aceite

# Tav.8

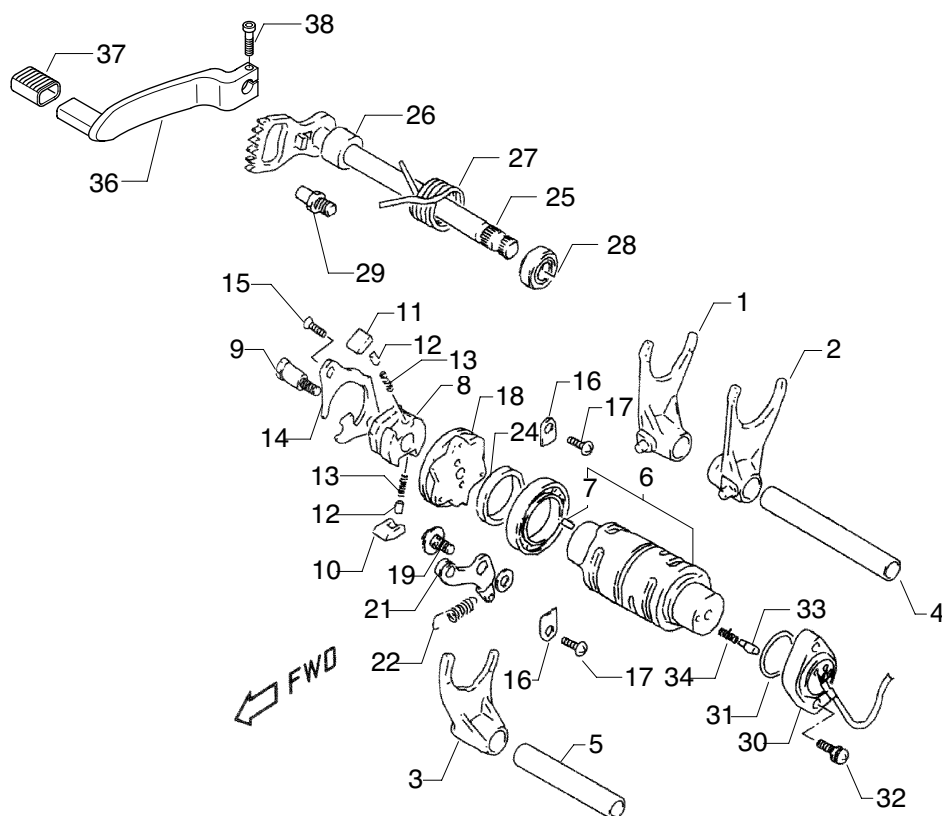

Pos Loc Pos Ps Pos	Numero Number Numéro Número Nummer	Nota Note Note Nota Anm.	Descrizione	Description	Désignation	Beschreibung	Descrìpziòn
1	3532800 000		Forca cambio marcia No. 1	Change gear fork No. 1	Fourche changement vitesse No. 1	Schaltgabel 1. Gang	Horquilla cambio velocidad N° 1
2	3532810 000		Forca cambio marcia No. 2	Change gear No. 2	Fourche changement vitesse No. 2	Schaltgabel 2. Gang	Horquilla cambio velocidad N° 2
3	3532820 000		Forca cambio marcia No. 3	Change gear No. 3	Fourche changement vitesse No. 3	Schaltgabel 3. Gang	Horquilla cambio velocidad N° 3
4	3533190 000		Tubetto L.95	L. 95 tube	Tuyau L. 95	Rohr L.95	Tube L.95
5	3533200 000		Tubetto L.70	L. 70 tube	Tuyau L. 70	Rohr L.70	Tube L.70
6	3533210 000		Camma comando cambio	Change gear control cam	Came commande chang. vitesse	Schaltnocke	Cama mando cambio
7	3533220 000		Spina fissagg. camma comando cambio	Change gear control cam lock pin	Came commande changement vitesse	Schaltnocken- Befestigungsstift	Perno fijación cama mando cambio
8	3521920 000		Camma	Cam	Came	Nocke	Cama
9	3533230 000		Spina fissaggio selettore	Selector lock pin	Goupille arrêt sélecteur	Befestigungsstift Gangwahl	Perno fijación selector
10	3511930 000		Dente d'arresto	Detent	Cran de blocage	Sperrzahn	Diente de tope
11	3511940 000		Dente d'arresto	Detent	Cran de blocage	Sperrzahn	Diente de tope
12	3511950 000		Rullino 5x8	Roller (5x8)	Rouleau (5x8)	Rolle 5x8	Rodillo 5x8
13	3511960 000		Molla	Spring	Ressort	Feder	Muelle
14	3511970 000		Piastrina denti d'arresto	Detent plate	Plaque crans de blocage	Sperrzahnblech	Placa dientes de tope
15	3511661 000		Vite	Screw	Vis	Schraube	Tornillo
16	3533240 000		Piastra fissaggio	Fastening plate	Plaque de fixation	Befestigungsblech	Placa fijación
17	3531070 000		Vite	Screw	Vis	Schraube	Tornillo
18	3533250 000		Piastra fissaggio	Fastening plate	Plaque de fixation	Befestigungsblech	Placa fijación
19	3533260 000		Bullone, coperchio selezione camma	Bolt, cam selection cover	Boulon, couvercle sélection came	Schraubbolzen, Schaltnockendeckel	Perno, tapa selección cama
20	3511992 000		Rondella	Washer	Rondelle	Unterlegscheibe	Arandela
21	3533270 000		Coperchio fissaggio camma	Cam fastening cover	Couvercle fixation came	Deckel Nockenbefestigung	Tapa fijación cama
22	35332620 000		Molla	Spring	Ressort	Feder	Muelle
23	3533280 000		Cuscinetto dx camma	Right cam bearing	Palier droit came	Rechtes Nockenlager	Rodamiento der. Cama
24	3533290 000		Rondella (25x32x5,63)	Washer (25x32x5,63)	Rondelle (25x32x5,63)	Unterlegscheibe (25x32x5,63)	Arandela (25x32x5,63)
25	3532830 000		Albero, cambio marcia	Shaft, change gear	Arbre, changement vitesse	Schaltwelle	Eje cambio velocidad
26	3512090 000		Distanziale 12x20x15,3	Spacer (12x20x15.3)	Entretoise (12x20x15,3)	Abstandhalter 12x20x15,3	Pasador 12x20x15,3
27	3532630 000		Molla	Spring	Ressort	Feder	Muelle
28	3512120 000		Anello paraolio 12x22x9	Oil seal unit (12x22x9)	Anneau pare-huile (12x22x9)	Öldichtring 12x22x9	Retén de aceite 12x22x9
29	3533300 000		Fissaggio asta cambio marce	Change gear rod fastening	Fixation tige changement vitesse	Schaltwellenbefestigung	Fijación asta cambio velocidad
30	3533730 000		Sensore	Sensor	Captur	Sensor	Sensor
31	3530540 000		O ring (D: 2,4, ID: 26,2)	O-Ring (D: 2,4 ID: 26,2)	O Ring (Diam: 2,4 Int: 26,2)	O-Ring (D: 2,4, ID: 26,2)	Anillo O-Ring (D:2,4, ID26,2)
32	3533330 000		Vite	Screw	Vis	Schraube	Tornillo
33	3512220 000		Contacto	Contact	Contact	Kontakt	Contacto
34	3512230 000		Molla	Spring	Ressort	Feder	Muelle
36	2121137 000		Leva comando cambio	Gear-change lever	Lever de sélection	Schalthebel	Palanca mando cambio
37	1629590 000		Gommino x mozzetto leva	Rubber buffer	Caoutchouc	Gummi	Goma
38	1149070 000		Bullone 6 x 20	6 x 20 bolt	Boulon 6 x 20	Schraubbolzen 6 x 20	Tornillo 6 x 20



# Tav.9

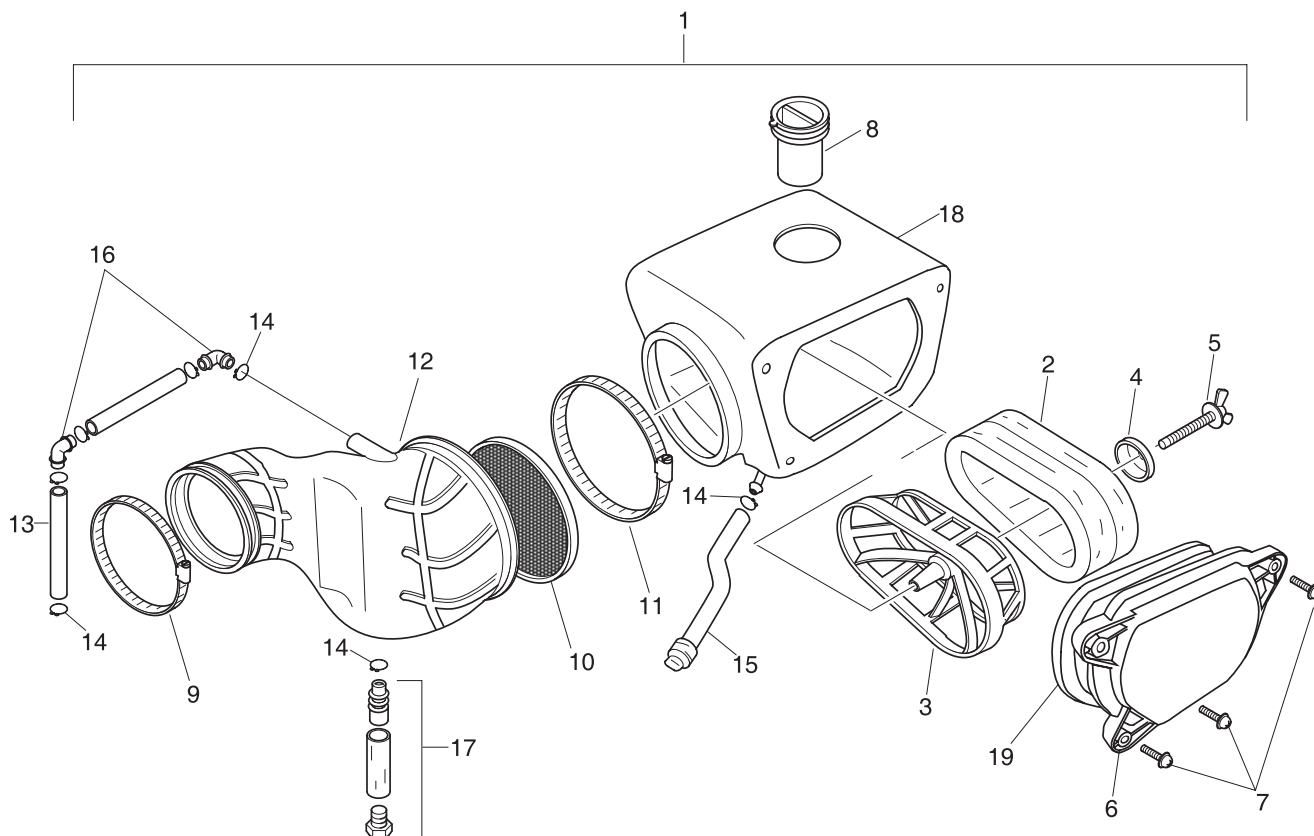

Pos Loc Pos Ps Pos	Numero Number Número Número	Nota Note Note Nota Anm.	Descrizione	Description	Désignation	Beschreibung	Descrìcion
1	2812748 800		Scatola filtro	Filter box	Boîtier filtre	Filtergehäuse	Caja filtro
2	1525094 800		Filtro aria 350 cc	Air filtre 350 cc	Filtre éponge 350 cc	Schwammfilter 350 cc	Filtro de esponja 350 cc
3	1611817 000		Contenitore filtro	Filter holder	Boîtier filtre	Filterboden mit Einsatz	Fondillo filtro
4	2764596 000		Rondella vite spec. filtro	Special filter screw washer	Rondelle vis spéc. filtre	Spezial-unterlegscheibe	Arandela especial
5	3163663 000		Vite speciale filtro	Special filter screw	Vis spéciale filtre	Spezial-schraube	Tornillo especial
6	1273216 159		Coperchio filtro aria	Filter box cover	Couvercle boîtier de filtre	Deckel Filtergehäuse	Tapa caja filtro
7	3533800 000		Vite coperchio filtro aria	Air filter cover screw	Vis couvercle filtre à air	Luftfiltergehäuse Schraube	Tapa filtro de aire tornillo
8	3533810 000		Preso aria scatola filtro	Filter box air intake	Prise d'air boîtier de filtre	Ansaugstutzen Filtergehäuse	Toma aire caja filtro
9	1514272 000		Fascetta raccordo aspirazione	Suction fitting clamp	Collier serrage raccord aspiration	Schelle Ansaugstutzen	Abrazadera racor aspiración
10	2733961 000		Rompifiamma	Flash break	Coupe-feu	Flamme damper	Damper de la llama
11	3533820 000		Fascetta s. filtro / manicotto	Box filter/hose clamp	Collier s. filtre / manchon	Schelle	Abrazadera
12	2213648 000		Manicotto scatola filtro	Filter box sleeve	Manchon boîte du filtre	Filtergehäuseumuffe	Manguito caja filtro
13	2915834 000		Tubo completo manicotto sc. filtro	Complete box filter hose	Tube complet manchon boîtier du filtre	Schlauch	Tubo
14	1067470 000		Anello string scatola filtro	Box filter string ring	Bague de serrage boîtier du filtre	Luftfiltergehäuse Ring	Anillo caja filtro
15	3533830 000		Tubo scarico scat. filtro	Box filter outlet	Bouchon tuyau	Krummer	Tubo de escape
16	2711020 000		Raccordo 90°	Joint.p. 90°	Raccord 90°	Stutzen 90°	Racor
17	2915835 000		Tubo scarico manic. sc. filtro	Box filter hose outlet	Tuyau de purge manchon boîtier du filtre	Krummer	Tubo de escape
18	2812758 000		Scatola filtro nuda	Filter box	Boîtier filtre nu	Leeres Filtergehäuse	Caja filtro
19	1677612 000		Guarnizione filtro	Packing	Joint du filtre	Filterdichtung	Junta

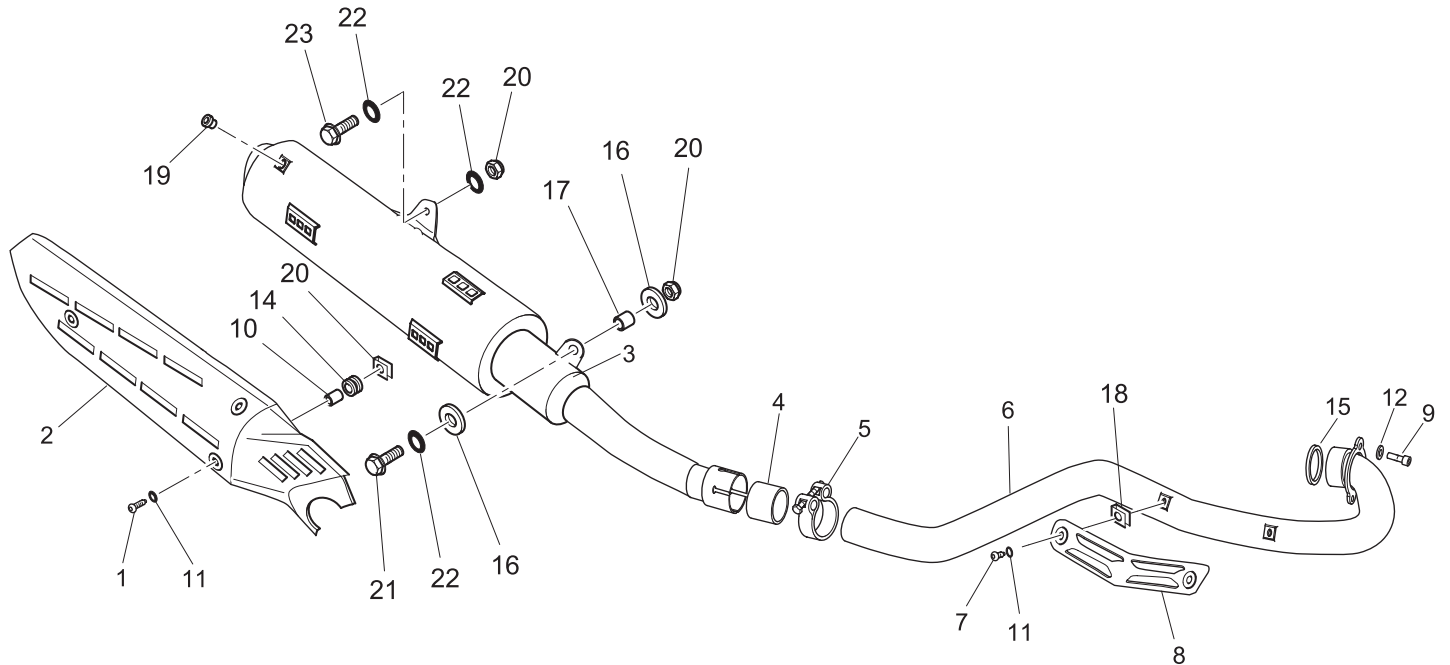

Pos Loc Pos Ps Pos	Numero Number Número Número	Nota Note Note Nota Anm.	Descrizione	Description	Désignation	Beschreibung	Descripción
1	3196802 000		Vite copertura marmitta	Silencer shield screw	Vis protection	Schraube Auspuffverkleidung	Tornillo cubre escape
2	2598933 014		Protez.marmitta grigio alluminio	Silencer shield	Protection silencieux	Auspuffverkleidung	Protección escape
3	2204178 000	Euro 3	Marmitta	Exhaust pipe	Pot d'échappem.	Schalldämpfer	Escape
4	1680813 000		Guarnizione marmitta	Silencer gasket	Garniture pot d'échappement	Dichtung Schalldämpfer	Junta escape
5	1514255 000		Fascetta marmitta	Silencer clamp	Collier serrage pot d'échap.	Schelle Schalldämpfer	Abrazadera escape
6	2916236 000	Euro 3	Tubo scarico	Exhaust pipe	Tuyau d'échappement	Auspuffrohr	Tubo de escape
7	3196802 000		Vite copertura marmitta	Silencer shield screw	Vis protection	Schraube Auspuffverkleidung	Tornillo cubre escape
8	2598917 014		Protezione tubo scarico	Exhaust pipe protection	Protection tuyau d'échapp.	Auspuffrohrverkleidung	Protección tubo escape
9	3163900 000		Vite 8 x 25	8 x 25 Screw	Vis 8 x 25	Schraube 8 x 25	Tornillo 8 x 25
10	1348858 000		Distanziale	Spacer	Entretoise	Abstandhalter	Pasador
11	1647491 000		Guarnizione coprimarmitta	Silencer gasket	Garniture pot d'échappement	Dichtung Schalldämpfer	Junta escape
12	2749500 000		Rondella grower	Grower washer	Rondelle Grower	Federring Grower	Arandela elástica Grower
14	2891880 000		Silent block	Silentbloc	Silentbloc	Silent block	Silent block
15	1680230 000		Guarnizione marmitta	Silencer gasket	Garniture pot d'échappement	Dichtung Schalldämpfer	Junta escape
16	1348866 000		Distanziale	Spacer	Entretoise	Abstandhalter	Pasador
17	2891953 000		Silent block	Silentbloc	Silentbloc	Silent block	Silent block
18	2560311 000		Piastrina	Spring plate	Plaquette élastique	Plättchen	Pletina elástica
19	1633781 000		Gommino	Rubber buffer	Caoutchouc	Gummi U-Scheibe	Goma
20	1317020 000		Dado autoblocc. M6	Self locking nut M6	Ecrou de sécurité M6	Mutter, selbstsichernd M6	Tuerca de seguridad M6
21	1155470 000		Vite 8 x 35	8 x 35 Screw	Vis 8 x 35	Schraube 8 x 35	Tornillo 8 x 35
22	2749500 000		Rondella 8 x 18	Washer 8 x 18	Rondelle 8 x 18	Unterlegscheibe 8 x 18	Arandela 8 x 18
23	1154492 000		Vite 8 x 20	8 x 20 Screw	Vis 8 x 20	Schraube 8 x 20	Tornillo 8 x 20

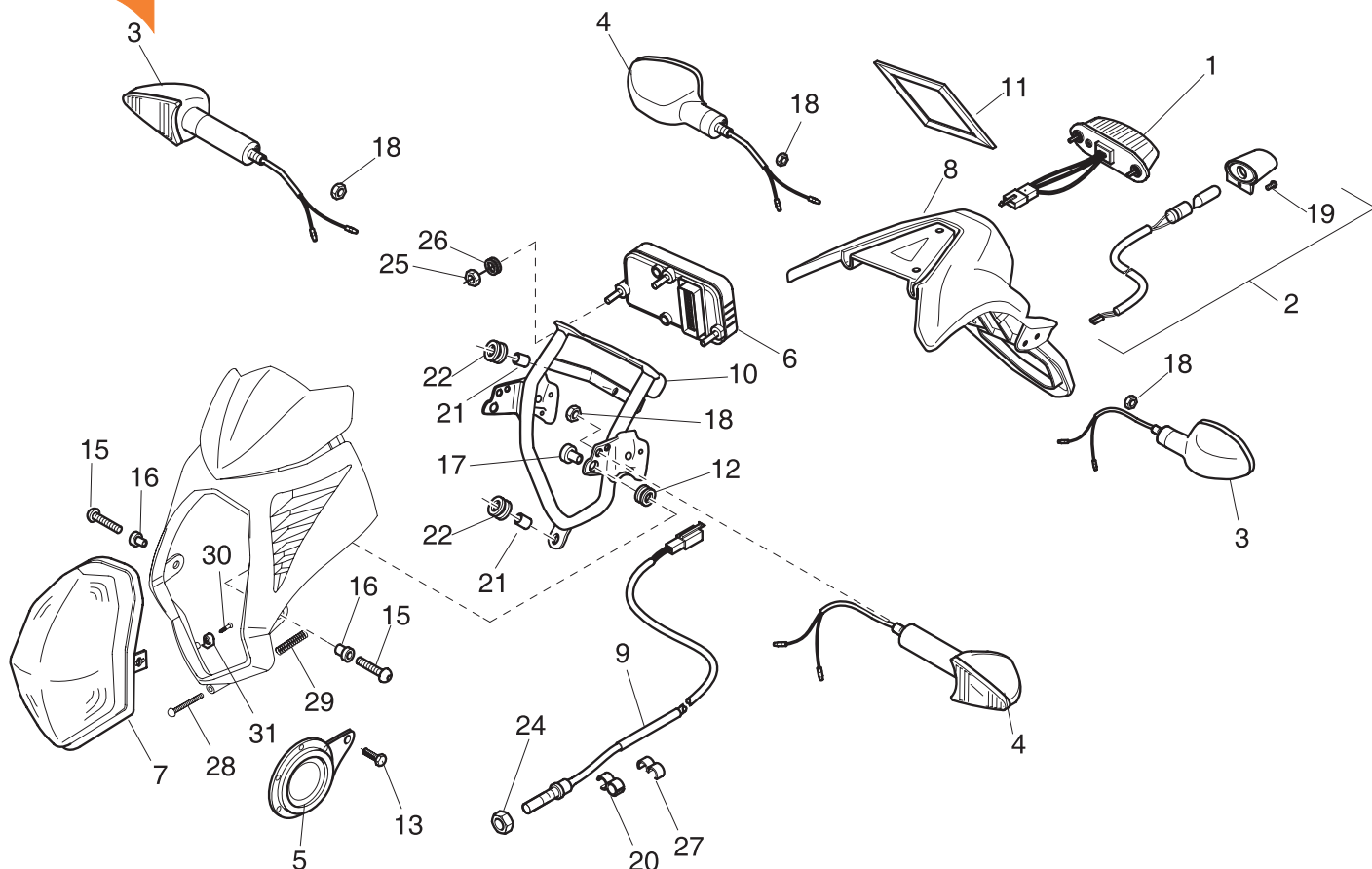

Pos Loc Pos Ps Pos	Numero Number Numéro Número Nummer	Nota Note Note Nota Anm.	Descrizione	Description	Désignation	Beschreibung	Descripción
1	1501872 000		Fanalino post.	Rear light	Régulateur	Rücklicht	Piloto trasero
2	2182060 000		Luce targa	Number plate lamp	Eclaireur	Nummernschildbeleuchtung	Luz matrícula
3	1812682 000		Ind.dir.A.dx-P.sx	RH front & LH rear turn indicators	Cligno. AV.D.-AR.G	Blinker vorne rechts - hinten links	Ind. Direc. Del. Der. Tras. Izq.
4	1812692 000		Ind.dir.A.sx-P.dx	LH front & RH rear turn indicators	Cligno. AV.G.-AR.D.	Blinker vorne links - hinten rechts	Ind. Direc. Del. Izq. Tras. Der
5	1009171 000		Avvisat.acustico c/staffa	Horn	Support planche	Hupe	Clacson
6	1209374 000		Conta Km	Speedometer	Compte-km	Kilometerzähler	Cuenta kilometros
7	1646208 000		Gruppo ottico	Semi sealed beam unit	Groupe optique	Scheinwerfer	Grupo óptico
8	2594485 159		Portatarga	Number plate holder	Support de plaque	Nummernschildhalter	Portamatrícula
9	2879012 000		Sensore velocità	Speed sensor	Captur vitesse	Geschwindigkeitsensor	Sensor velocidad
10	2898074 025		Supporto strumenti -vern.	Instrument panel support	Support planche	Instrumentenhalter	Soporte instrumentos
11	2898476 000		Supporto targa	Number plate holder	Support de plaque	Nummernschildhalter	Portamatrícula
12	2891500 000		Silent block	Silentbloc	Silentbloc	Silent block	Silent block
13	1146501 000		Bullone 6 x 10	6 x 10 bolt	Boulon 6 x 10	Schraubbolzen 6 x 10	Tornillo 6 x 10
15	1149070 000		Bullone 8 x 20	8 x 20 bolt	Boulon 8 x 20	Schraubbolzen 8 x 20	Tornillo 8 x 20
16	1354820 000		Distanziale	Spacer	Entretoise	Distanzstück	Distanciadador
17	1362012 000		Distanziale	Spacer	Entretoise	Distanzstück	Distanciadador
18	1312550 000		Dado 6 flang.	Nut 6	Ecrou 6	Mutter 6	Tuerca 6
19	3123500 000		Vite 4 x 13	4 x 13 screw	Vis 4 x 13	Schraube 4 x 13	Tornillo 4 x 13
20	2524442 000		Passacavo doppio tipo 6/8	Grommet 6/8	Passe-câble 6/8	Kabeldurchgang 6/8	Pasacables 6/8
21	1128500 000		Boccola	Bush	Moyeu	Büchse	Buje
22	2891500 000		Silent block	Silentbloc	Silentbloc	Silent block	Silent block
23	1634906 000		Gommino portatarga	Rubber buffer	Caoutchouc	Gummi	Goma
24	1317121 000		Dado speciale	Special nut	Ecrou spécial	Speziālschmutter	Tuerca speciale
25	1321848 000		Dado speciale	Special nut	Ecrou spécial	Speziālschmutter	Tuerca speciale
26	1634905 000		Gommino supporto strumenti	Rubber instrument panel support	Caoutchouc support planche	Gummi Instrumentenhalter	Goma soporte instrumentos
27	2524443 000		Passacavo doppio tipo 6/6	Grommet 6/6	Passe-câble 6/6	Kabeldurchgang 6/6	Pasacables 6/6
28	3128520 000		Vite 4 x 35	4 x 35 screw	Vis 4 x 35	Schraube 4 x 35	Tornillo 4 x 35
29	2280500 000		Molla regolazione faro ant.	Front bracket adjusting spring	Ressort de réglage projecteur AV.	Scheinwerfer Feder, Einstell	Muelle de regul. faro del.
30	3122560 000		Vite 2,9 x 13	2,9 x 13 screw	Vis 2,9 x 13	Schraube 2,9 x 13	Tornillo 2,9 x 13
31	1001010 159		Aggancio gruppo ottico	Beam unit hook	Crochet groupe optique	Haken scheinwerfer	Enganche grupo óptico

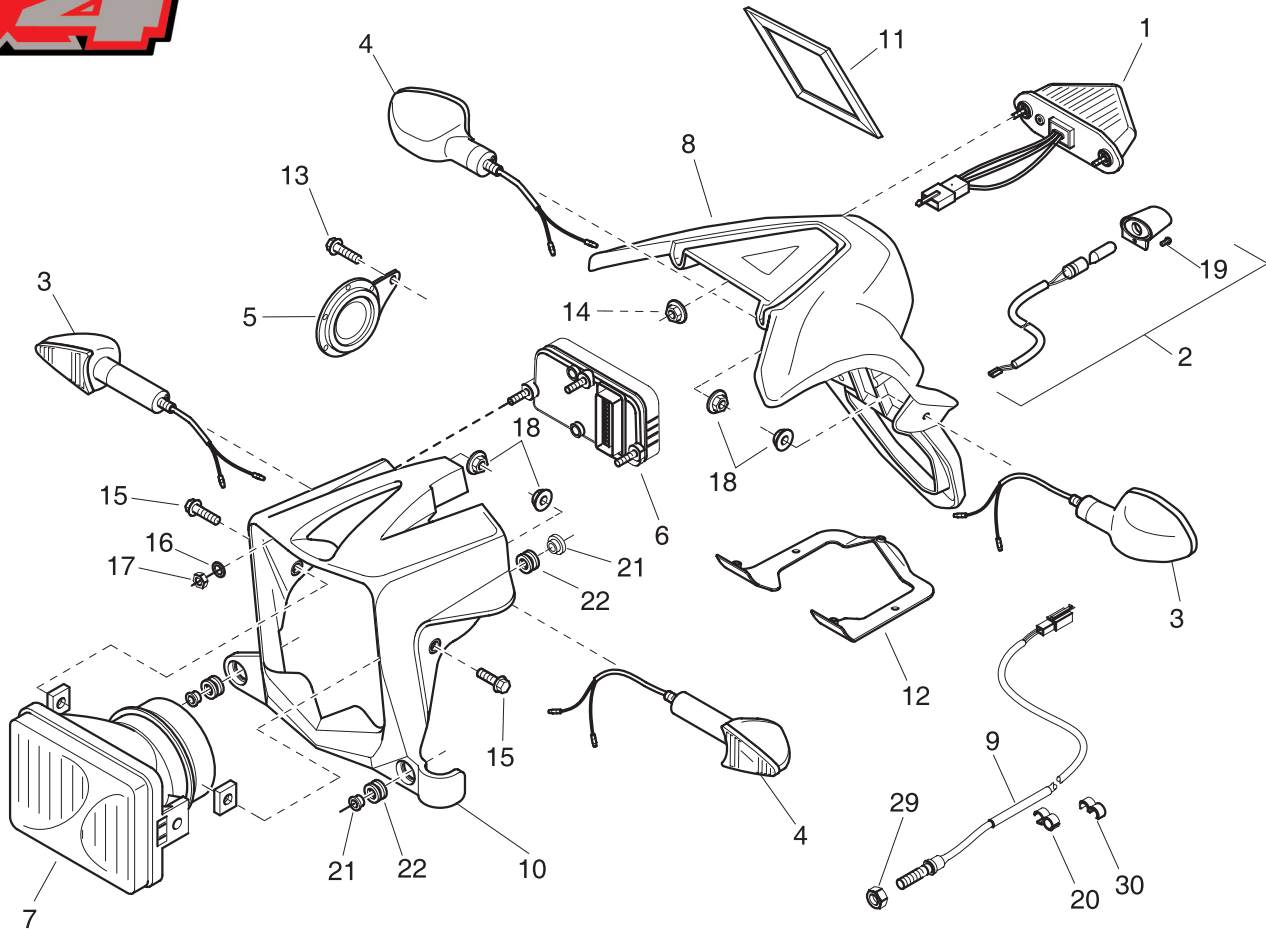

Pos Loc Pos Ps Pos	Numero Number Número Nummer	Nota Note Nota Anm.	Descrizione	Description	Désignation	Beschreibung	Descripción
1	1501871 000		Fanalino post.	Rear light	Régulateur	Rücklicht	Piloto trasero
2	2182060 000		Luce targa	Number plate lamp	Eclairer	Nummerschildbeleuchtung	Luz matrícula
3	1812682 000		Ind.dir.A.dx-P.sx	RH front & LH rear turn indicators	Cligno. AV.D.-AR.G	Blinker vorne rechts - hinten links	Ind. Direc. Del. Der. Tras. Izq.
4	1812692 000		Ind.dir.A.sx-P.dx	LH front & RH rear turn indicators	Cligno. AV.G.-AR.D.	Blinker vorne links - hinten rechts	Ind. Direc. Del. Izq. Tras. Der
5	1009171 000		Avvisat.acustico c/staffa	Horn	Support planche	Hupe	Clacson
6	1209369 000		Conta Km	Speedometer	Compte-km	Kilometerzähler	Cuenta kilometros
7	1646202 000		Gruppo ottico	Semi sealed beam unit	Groupe optique	Scheinwerfer	Grupo óptico
8	2594487 059		Portatarga	Number plate holder	Support de plaque	Nummernschildhalter	Portamatrícula
9	2879010 000		Sensore velocità	Speed sensor	Capteur vitesse	Geschwindigkeitsensor	Sensor velocidad
10	2228473 059		Supporto strumenti -mascherina	Instrument panel support - Mask	Support planche - Calandre	Instrumentenhalter - Scheinwerfermaske	Soporte instrumentos - protección
11	2898476 000		Supporto targa	Number plate holder	Support de plaque	Nummernschildhalter	Portamatrícula
12	2598636 000		Protezione impianto elettrico	Wiring guard	Protection cablage électrique	Abdeckung electroverkabelung	Protección cableado eléctrico
13	1146501 000		Bullone 6 x 10	6 x 10 bolt	Boulon 6 x 10	Schraubbolzen 6 x 10	Tornillo 6 x 10
14	1312550 000		Dado	Nut	Ecrou	Mutter	Tuerca
15	3130520 000		Vite 6 x 16	6 x 16 screw	Vis 6 x 16	Schraube 6 x 16	Tornillo 6 x 16
16	2736000 000		Rondella 5 x 11	Rove 5 x 11	Rondelle 5 x 11	U.Scheibe 5 x 11	Arandela 5 x 11
17	1311000 000		Dado 5.5	Nut 5.5	Ecrou 5.5	Mutter 5.5	Tuerca 5.5
18	1312550 000		Dado 6 flang.	Nut 6	Ecrou 6	Mutter 6	Tuerca 6
19	3123500 000		Vite 4 x 13	4 x 13 screw	Vis 4 x 13	Schraube 4 x 13	Tornillo 4 x 13
20	2524442 000		Passacavo doppio tipo 6/8	Grommet 6/8	Passe-câble 6/8	Kabeldurchgang 6/8	Pasacables 6/8
21	1346377 000		Distanziale	Spacer	Entretoise	Abstandhalter	Pasador
22	2891500 000		Silent block	Silentbloc	Silentbloc	Silent block	Silent block
29	1317121 000		Dado speciale	Special nut	Ecrou spécial	Speziālsmutter	Tuerca especial
30	2524443 000		Passacavo doppio tipo 6/6	Grommet 6/6	Passe-câble 6/6	Kabeldurchgang 6/6	Pasacables 6/6



# Tav.12

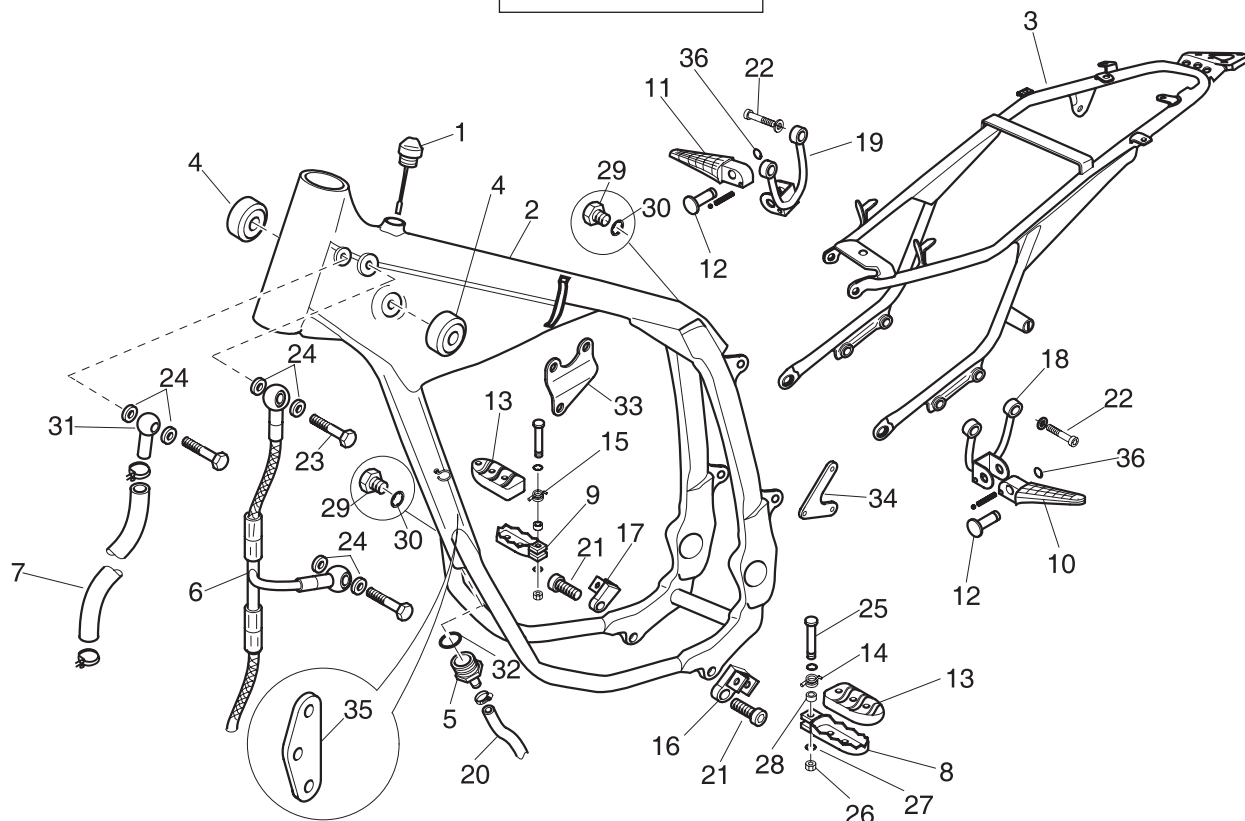

Pos Loc Pos Ps Pos	Numero Number Numéro Número Nummer	Nota Note Note Nota Anm.	Descrizione	Description	Désignation	Beschreibung	Descripción
1	2910535 000		Tappo con asta contr. olio	Oil dipstick plug	Bouchon-jauge	Öldeckel komplett	Tapa aceite completo
2	2911567 025		Telaio anteriore	Front frame	Cadre AV.	Vorderer Rahmen	Bastidor delantero
3	2911432 025	Alp 4.0	Telaio posteriore - verniciato	Rear frame - varnished	Cadre arrière peint	Fahrgestell hinten	Bastidor trasero
3	2911434 025	M4	Telaio posteriore - verniciato	Rear frame - varnished	Cadre arrière peint	Fahrgestell hinten	Bastidor trasero
4	2910315 000		Tampone serbatoio	Fuel tank pad	Silentbloc réservoir	Puffer Tank	Tampón depósito combustible
5	2711265 000		Tappo in uscita serb. olio	Oil tank exit plug	Bouchon sortie réservoir d'huile	Verschluß	Tapón
6	2915836 000		Tubo in entrata serb.olio	Oil tank entry pipe	Tuyau entrée réservoir d'huile	Schlauch	Tubo
7	2915815 000		Tubo di gomma 5x10	Rubber hose 5x10	Tuyau en caoutchouc 5x10	Gummileitung 5x10	Tubo de goma 5x10
8	2532530 000		Pedana p/piedi sx	LH footrest	Cale-pied G	Fußraste links	Estribo pié izq
9	2532520 000		Pedana p/piedi dx	RH footrest	Cale-pied D	Fußraste rechts	Estribo pié der
10	2532512 000		Pedana p/piedi pass.ro sx	LH passenger's footrest	Cale-pied AR.G.	Linker Beifahrer-Fußraste	Estribo pié pasajero izq
11	2532502 000		Pedana p/piedi pass.ro dx	RH passenger's footrest	Cale-pied AR.D.	Rechter Beifahrer-Fußraste	Estribo pié pasajero der
12	2554460 000		Perno snodo pedana pass.ro	Passenger's footrest joint pin	Axe art. cale-pied AR.	Gelenkzapfen Beifahrer-Fußraste	Perno articulado estribo pasajero
13	1623202 000		Gomma pedana poggiapiedi	Footrest rubber	Caoutchouc cale-pied	Fußrastengummi	Goma estribo apoya pié
14	2262010 000		Molla pedana dx trial ed enduro	Trial and Enduro r. footboard spring	Ressort plate-forme droite trial et enduro	Feder fußblech rechts	Muelle estribo der.
15	2262020 000		Molla pedana sx trial ed enduro	Trial and Enduro l. footboard spring	Ressort plate-forme gauche trial et enduro	Feder fußblech links	Muelle estribo izq.
16	2809521 025		Supp. pedana pilota sx	LH rider's footrest support	Support cale-pied AV.G.	Linker Halter Beifahrer-Fußraste	Sop. Estribo pilota izq
17	2809520 025		Supp. pedana pilota dx	RH rider's footrest support	Support cale-pied AV.D.	Rechter Halter Beifahrer-Fußraste	Soporte estribo pilota der
18	2809519 025		Supp. pedana pass.ro sx	LH passenger's footrest support	Support cale-pied AR.G.	Linker Halter Beifahrer-Fußraste	Soporte pedana pasajero izq
19	2809518 025		Supp. pedana pass.ro dx	RH passenger's footrest support	Support cale-pied AR.D.	Rechter Halter Beifahrer-Fußraste	Soporte estribo pasajero der
20	2915837 000		Tubo in uscita serb. olio	Oil tank exit pipe	Tuyau sortie réservoir d'huile	Schlauch	Tubo
21	3165290 000		Vite 10 x 20	Screw 10 x 20	Vis 10 x 20	Schraube 10 x 20	Tornillo 10 x 20
22	3163880 000		Vite brugola 8 x 16	8 x 16 socket head screw	Vis à six pans 8 x 16	Inbusschraube 8 x 16	Tornillo Allen 8 x 16
23	1148025 000		Bullone 6 x 10	Bolt 6 x 10	Boulon 6 x 10	Bolzen 6 x 10	Perno 6 x 10
24	1650510 000		Rondella rame 10 x 15 x 1	Rove	Rondelle cuivre	Kupfer U.Scheibe	Arandela de cobre
25	1155690 000		Bullone 8 x 45	Bolt 8 x 45	Boulon 8 x 45	Bolzen 8 x 45	Perno 8 x 45
26	1317020 000		Dado 8 basso	Bottom 8 nut	ecrou 8 a blocage automatique bas	Mutter 8	Tuerca 8
27	2749500 000		Rondella 8 x 18	Washer 8 x 18	Rondelle 8 x 18	Unterlegscheibe 8 x 18	Arandela 8 x 18
28	1346530 000		Distanziale 8 x 12 x 17	Spacer 8 x 12 x 17	Entretoise 8 x 12 x 17	Abstandhalter 8 x 12 x 17	Pasador 8 x 12 x 17
29	1146501 000		Bullone 6 x 10	Bolt 6 x 10	Boulon 6 x 10	Bolzen 6 x 10	Perno 6 x 10
30	2740490 000		Rondella Ø 6 rame	Copper washer Ø 6	Rondelle cuivre Ø 6	Kupfer U.Scheibe Ø 6	Arandela de cobre Ø 6
31	2723465 000		Raccordo occhio 10 SV 1/4	10 SV 1/4 Eye joint	Raccord-boule 10 SV 1/4	Stutzen 10 SV 1/4	Racor 10 SV 1/4
32	3510480 000		Anello OR 3.1-22.7	3.1-22.7 OR ring	Joint torique 3.1-22.7	O-Ring 3.1-22.7	Anillo OR 3.1-22.7
33	2557684 000		Piastra supporto testa motore	Engine head support plate	Plaque de support culasse moteur	Befestigung Motorkopf	Chapa soporte culata motor
34	2557682 000		Piastra supporto motore post.	Rear engine support plate	Plaque de support moteur arrière	Befestigung Motorkopf	Chapa soporte culata motor tras.
35	2557681 000		Piastra supporto motore ant.	Front engine support plate	Plaque de support moteur avant	Befestigung Motorkopf	Chapa soporte culata motor del.
36	2822550 000		Seeger RA4	Snap ring RA4	Anneau de retenue RA4	Seegerring RA4	Anillo seeger RA4
37	2891390.000		Silent block	Silent block	Silent block	Silent block	Silent block
38	1650517.000		Guarnizione in rame	Copper gasket	Joint cuivre	Kupfer Dichtung	Junta de cobre
39	1650515.000		Guarnizione in rame	Copper gasket	Joint cuivre	Kupfer Dichtung	Junta de cobre
40	1165040.000		Bullone	Bolt	Boulon	Bolzen	Perno

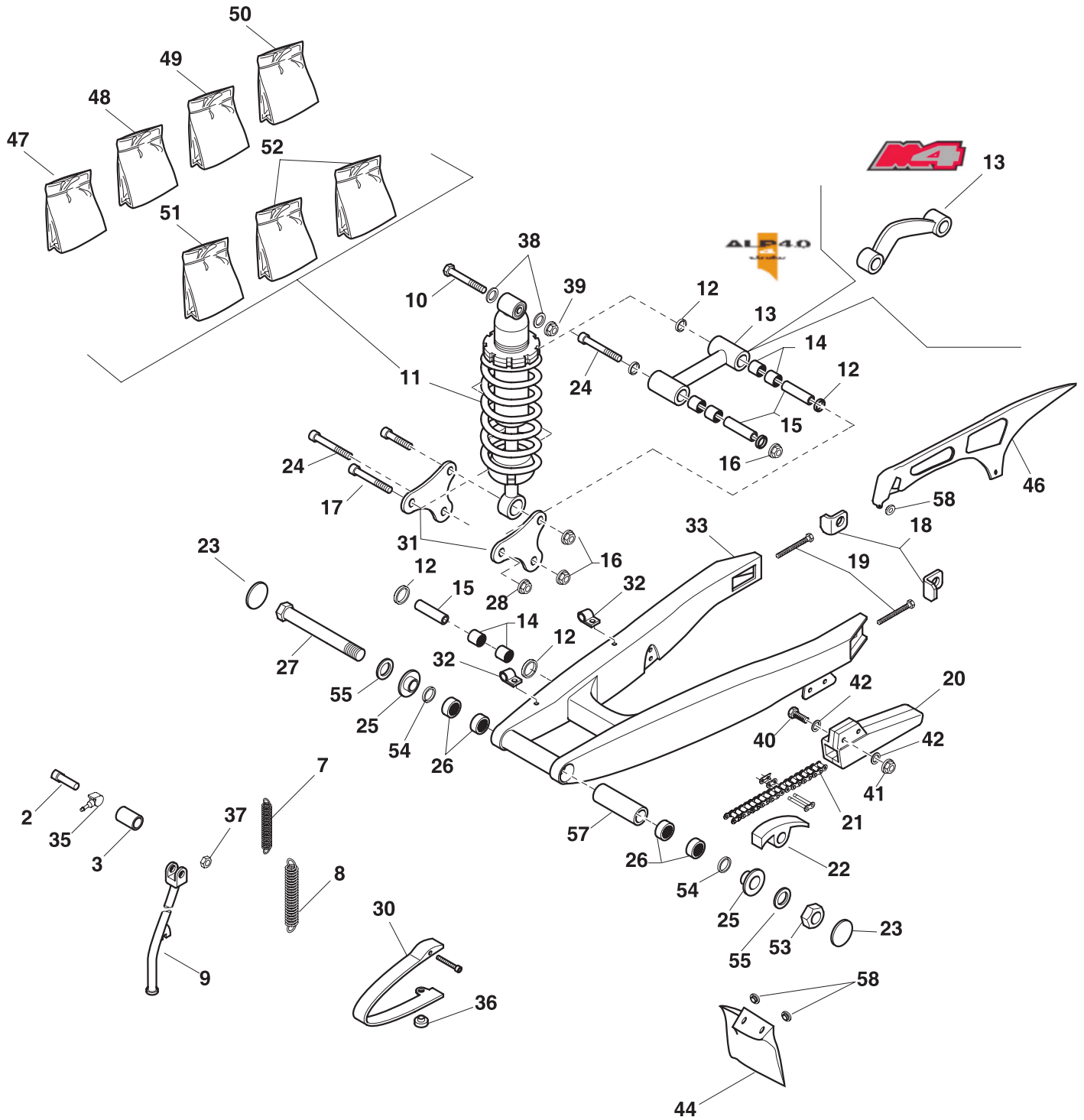

# Tav.13

Pos Loc Pos Ps Pos	Numero Number Numéro Número Nummer	Nota Note Note Nota Anm.	Descrizione	Description	Désignation	Beschreibung	Descripción
2	1170010 000		Bullone spec.cavalletto	Special stand bolt	Boulon béquille	Spezialbolzen. Ständer	Perno especial caballete
3	1346350 000		Distanziale cavalletto	Stand spacer	Entretoise béquille	Abstandhalter Ständer	Distanciadior caballete
7	2247019 000		Molla cavall.interna	Stand inner spring	Ressort béquille int.	Innere Ständerfeder	Muelle caballete interno
8	2247022 000		Molla cavall. esterna	Stand outer spring	Ressort béquille ext.	Äußere Ständerfeder	Muelle caballete externo
9	1239895 000	Alp 4.0	Cavalletto	Central stand	Béquille	Kippständer	Caballete
9	1239895 059	M4	Cavalletto	Central stand	Béquille	Kippständer	Caballete
10	1163000 000		Bullone 10x50	Bolt 10x50	Boulon 10x50	Bolzen 10x50	Perno 10x50
11	1003780 000	Alp 4.0	Ammortizzatore	Shock absorber	Amortisseur	Stoßdämpfer	Amortiguador
11	1003781 000	M4	Ammortizzatore	Shock absorber	Amortisseur	Stoßdämpfer	Amortiguador
12	1041195 000		Anello parapolvere	Dust cover ring	Joint poussière	Staubschutzring	Anillo guardapolvo
13	1119741 025	Alp 4.0	Bielletta	Rod	Biellette	Kleines Pleuel	Biela
13	1119739 025	M4	Bielletta	Rod	Biellette	Kleines Pleuel	Biela
14	1122850 000		Boccola a rulli	Roller bushing	Roulement à rouleaux	Rollenbuchse	Buje de rodillos
15	1348056 000		Distanziale	Spacer	Entretoise	Distanzstück	Distanciadior
16	1321120 000		Dado autobloccante M12	Self-locking nut (M12)	Ecrou autobloquant M12	Selbstsichernde Mutter M12	Tuerca autotrabadora
17	1163700 000		Bullone 10x65	Bolt 10x65	Boulon 10x65	Bolzen 10x65	Perno 10x65
18	2911864 000		Tendicatena	Chain tightener	Tendeur de chaîne	Kettenspanner	Tensor de cadena
19	1155909 000		Bullone 8x55	Bolt 8x55	Boulon 8x55	Bolzen 8x55	Perno 8x55
20	2910066 000		Tassello guida catena inf.	Lower chain guide block	Guide chaîne inf.	Einsatz untere Kettenführung	Guía cadena inferior
21	1207287 000	Alp 4.0	Catena	Chain	Chaîne	Kette	Cadena
21	1207286 000	M4	Catena	Chain	Chaîne	Kette	Cadena
22	2525601 000		Pattino guida catena	Chain shoe	Doigt chaîne	Gleitauflage	Patín cadena
23	1255900 000		Coperchietto dadi forcellone	Swing arm nut cover	Cache écrous bras osc.	Abdeckung Gabelmuttern	Tapa tuerca horquilla
24	3165995 000		Vite 12x70	Screw 12x70	Vis 12x70	Schraube 12x70	Tornillo 12x70
25	1348412 000		Distanziale forcellone	Spacer	Entretoise	Distanzstück	Distanciadior
26	1122980 000		Boccola a rulli	Roller bushing	Roulement à rouleaux	Rollenbuchse	Buje de rodillos
27	2547651 000		Perno forcellone	Swing arm pivot	Axe de pivotement	Gabelzapfen	Perno horquilla
28	1319010 000		Dado autobl. M10	Selflocking nut (M10)	Ecrou autobloquant M.10	Selbstsichernde Mutter M10	Tuerca autotrabadora
30	2910064 000		Tassello guida catena sup.	Upper chain guide block	Guide chaîne sup.	Einsatz obere Kettenführung	Guía cadena superior
31	2557245 000		Piastrina bilanciata	Rocker plate	Plaquette balancier	Schwinghebelblech	Placa balancin
32	1514602 000		Fascetta	Clamp	Collier	Schelle	Abrazadera
33	1549641 033	Alp 4.0	Forcellone	Swing arm	Bras oscillant	Gabel	Horquilla
33	1549643 059	M4	Forcellone	Swing arm	Bras oscillant	Gabel	Horquilla
35	1888320 000		Interr. cavalletto	Stand switch	Interr. béquille	Ständerschalter	Interruptor caballete
36	1382551 000		Distanziale	Spacer	Entretoise	Distanzstück	Distanciadior
37	1318000 000		Dado M10 x 6	M10 x 6 nut	Ecrou M10 x 6	Mutter M10 x 6	Tuerca M10 x 6
38	2754000 000		Rondella 10 x 21	Washer 10 x 21	Rondelle 10 x 21	Unterlegscheibe 10 x 21	Arandela 10 x 21
39	1319010 000		Dado M10 autobloccante basso	10 height self-locking nut	Ecrou auto-bloquant (M10) bas	Selbstsichernde Mutter M10 flach	Tuerca de seguridad M10 bajo
40	1150355 000		Bullone 6 x 35	Bolt 6 x 35	Boulon 6 x 35	Bolzen 6 x 35	Perno 6 x 35
41	1313010 000		Dado M6 alto	M6 nut	Ecrou M6	Mutter M6	Tuerca M6
42	2743250 000		Rondella 6 x 24	Washer 6 x 24	Rondelle 6 x 24	Unterlegscheibe 6 x 24	Arandela 6 x 24
44	2524415 059		Paraschizzi	Anti-splash	Pare-éclaboussures	Kotflügelappen	Gomas aislantes
46	1288590 059		Copricatena	Chain guard	Carter de chaîne	Kettenschutz	Cubrecadena
47	1620810 000		Ghiera di registro	Register ring nut	Bague de réglage	Gewindering	Casquillo
48	2910307 000		Tampone di battuta	Buffer	Tampon de butée	Anschlagpuffer	Tope goma
49	1382520 000		Distanziale per snodo	Joint spacer	Entretoise pour rotule	Distanzstück	Distanciadior
50	1677605 000		Guarnizione	Washer	Joint	Dichtung	Junta
51	2893015 000		Snodo	Joint	Rotule	Kopf	Articulación
52	2239130 000	Alp 4.0	Molla	Spring	Ressort	Feder	Muelle
52	2239131 000	M4	Molla	Spring	Ressort	Feder	Muelle
53	1329505 000		Dado 16x1,5	Nut 16x1,5	Ecrou 16x1,5	Mutter 16x1,5	Tuerca 16x1,5
54	1067545 000		Anello parapolvere	Dust cover ring	Joint poussière	Staubschutzring	Anillo guardapolvo
55	2771122 000		Rondella 17.30.3	Washer 17.30.3	Rondelle 17.30.3	Unterlegscheibe 17.30.3	Arandela 17.30.3
57	1348413 000		Distanziale int. forcellone	Internal fork spacer	Entretoise int. fourche	Distanzstück, inner	Distanciadior interno
58	1354510 000		Distanziale	Spacer	Entretoise	Distanzstück	Distanciadior

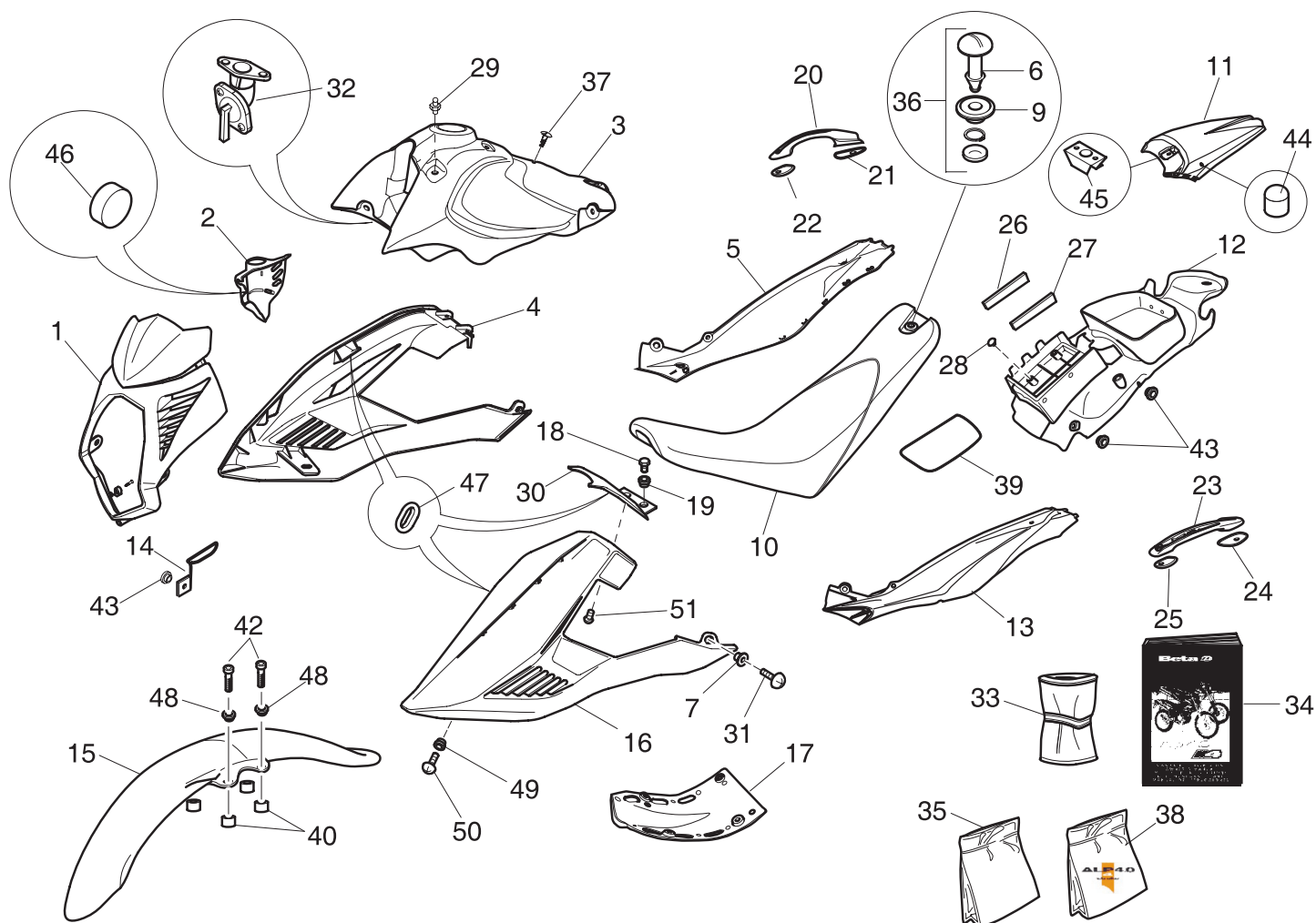



# Tav. 14

Pos Loc Pos Ps Pos	Numero Number Número Número Nummer	Nota Note Note Nota Anm.	Descrizione	Description	Désignation	Beschreibung	Descripción
1	2228476 OXX		Mascherina p/faro	Light mask	Calandre phare	Scheinwerfermaske	Protección faro
2	2598676 059		Protezione commutatore	Switch protection	Protection contacteur	Schalterschutz	Protección conmutador
3	2806082 059		Serbatoio	Fuel tank	Réservoir	Benzintank	Depósito
4	1519866 OXX		Fianchetto serbatoio destro	Fuel tank right side	Cache latéral réservoir droit	Seitenverkleidung r.	Carenado tanque der.
5	1519860 OXX		Fiancata posteriore destra	Rear right side	Cache latéral arrière droit	Seitenverkleidung hinten rechte	Carenado tr. der.
6	2544070 000		Perno	Pivot	Pivot	Welle	Perno
7	1362010 000		Distanziale	Spacer	Entretoise	Distanzstück	Distanciadior
9	2764597 000		Rondella	Washer	Rondelle	Unterlegscheibe	Arandela
10	2802655 000		Sella	Saddle	Selle	Sitzbank	Sillin
11	2519588 OXX		Parafango post.	Rear mudguard	Garde-boue arrière	Hinterer Kotflügel	Guardabarros tras.
12	2524659 059		Passaruota	Wheelhouse	Passage roue	Radkasten	Pasa-rueda
13	1519861 OXX		Fiancata posteriore sinistra	Rear left side	Cache latéral arrière gauche	Seitenverkleidung hinten links	Carenado tr. izq.
14	2525220 000		Passafili tubo freno	Brake pipe cable guide	passe-fils tube de frein	Kabeldurchgänge	Parsecable
15	2515198 OXX		Parafango ant.	Front mudguard	Garde boue AV.	Vorderradkotflügel	Parte del. guardab.
16	1519867 OXX		Fianchetto serbatoio sinistro	Fuel tank left side	Cache latéral réservoir gauche	Seitenverkleidung l.	Carenado tanque der.
17	1232206 059		Carter parasassi	Gravel guard	Sabot de protection	Steinschlag Schutzgehäuse	Carter protector
18	1146501 000		Bullone 6x10	6x10 Bolt	Boulon 6x10	Bolzen 6x10	Perno 6x10
19	1354510 000		Distanziale	Spacer	Entretoise	Distanzstück	Distanciadior
20	2200110 059		Maniglia passeggero dx	Right passenger grip	Poignée droite passager	Klinke für sozium r.	Manilla pasajero der.
21	1677603 000		Guarnizione maniglia post. dx	Rear right grip washer	Joint poignée arrière droite	Dichtung	Junta manilla tras. der.
22	1677601 000		Guarnizione maniglia ant. dx	Front right grip washer	Joint poignée avant droite	Dichtung	Junta manilla del. der.
23	2200111 059		Maniglia passeggero sx	Left passenger grip	Poignée gauche passager	Klinke für sozium l.	Manilla pasajero izq.
24	1677604 000		Guarnizione maniglia post. sx	Rear left grip washer	Joint poignée arrière gauche	Dichtung	Junta manilla del. izq.
25	1677602 000		Guarnizione maniglia ant. sx	Front left grip washer	Joint poignée avant gauche	Dichtung	Junta manilla del. izq.
26	2894951 000		Spugna batteria	Battery sponge	Eponge batterie	Gummi Batterie	Goma bateria
27	2894952 000		Spugna batteria lato sx	Left side battery sponge	Eponge batterie côté gauche	Gummi Batterie, Links	Goma bateria izq.
28	2910314 000		Tampone batteria	Battery buffer	Tampon batterie	Puffer batterie	Silent-block Bateria
29	2541840 000		Perno anc.fianc.serbatoio	Fuel tank side anch. pin	Axe anc. cache latéral réservoir	Zapfen für Anlenkung	Perno para eng.
30	3010020 059		Elemento collegamento fiancate	Side covers connection part	Pièce raccordement couvertures	Kupplungsteil Seitenverkleidung	Piexa de union prot. lat.
31	1148025 000		Bullone 6x16	6x16 Bolt	Boulon 6x16	Bolzen 6x16	Perno 6x16
32	2779602 000		Rubinetto benzina	Fuel cock	Robinet d'essence	Benzinhahn	Grifo gasolina
33	1105665 000		Borsezza con arnesi	Tool bag	Trousse à outils	Werkzeugtasche	Bolsa con útiles
34	2173283 100		Libretto istruzioni	Instruction manual	Livret d'instructions	Instruktionsbüchlein	Cuaderno instrucciones
35	1331447 500		Decalco per coperchi motore	Engine cover transfer	Décalcomanie pour couvercles moteur	Abziehbild Motordeckel	Calcomania tapa motor
36	2002043 000		Kit chiusura	Closure kit	Kit fermeture	Kit Schließvorrichtung	Kit cerradura
37	3189010.000		Vite	Screw	Vis	Schraube	Tornillo
38	1331472 OXX		Serie decalco	Transfer set	Série décalco	Serie Aufkleber	Serie adhesivos
39	1440045 000		Elastico fermabatteria	Battery elastic strap	Sangle batterie	Gummiband Batteriebefestigung	Elastico sujeta batería
40	1346411 000		Distanziale 6,5.15.10 -ALL-	6,5.15.10 -ALL- Spacer	Entretoise 6,5.15.10 -ALL-	Abstandhalter 6,5.15.10 -ALL-	Pasador 6,5.15.10 -ALL-
42	1150010 000		Bullone 6.25 RS CH 8	6.25 RS CH 8 Bolt	Boulon 6.25 RS CH 8	Bolzen 6.25 RS CH 8	Perno 6.25 RS CH 8
43	1354510 000		Distanziale	Spacer	Entretoise	Distanzstück	Distanciadior
44	1629493 000		Gommino	Rubber	Rondelle	Gummi U-Scheibe	Goma
45	1254270 000		Clips chiusura 1/4 giro	1/4 turn closure clips	Clips fermeture 1/4 de tour	Clips	Clips
46	1638100 000		Gommino	Rubber	Rondelle	Gummi U-Scheibe	Goma
47	1634900 000		Gommino	Rubber	Rondelle	Gummi U-Scheibe	Goma
48	1362251 000		Distanziale	Spacer	Entretoise	Distanzstück	Distanciadior
49	1354510 000		Distanziale	Spacer	Entretoise	Distanzstück	Distanciadior
50	3130080 000		Vite 5x10	Screw 5x10	Vis 5x10	Schraube 5x10	Tornillo 5x10
51	3130080 000		Vite 5x10	Screw 5x10	Vis 5x10	Schraube 5x10	Tornillo 5x10

OXX	
098	Bianco perla - Pearl white - Blanc Perle - Perle Weiß - Blanco perla
094	Arancio - Orange - Orange - Orange - Anaranjado
052	Nero lucido - Glossy black - Noir brillant - Glänzend Schwarz - Negro brillante
014	Grigio acrilico - Grey - Gris - Grau - Gris

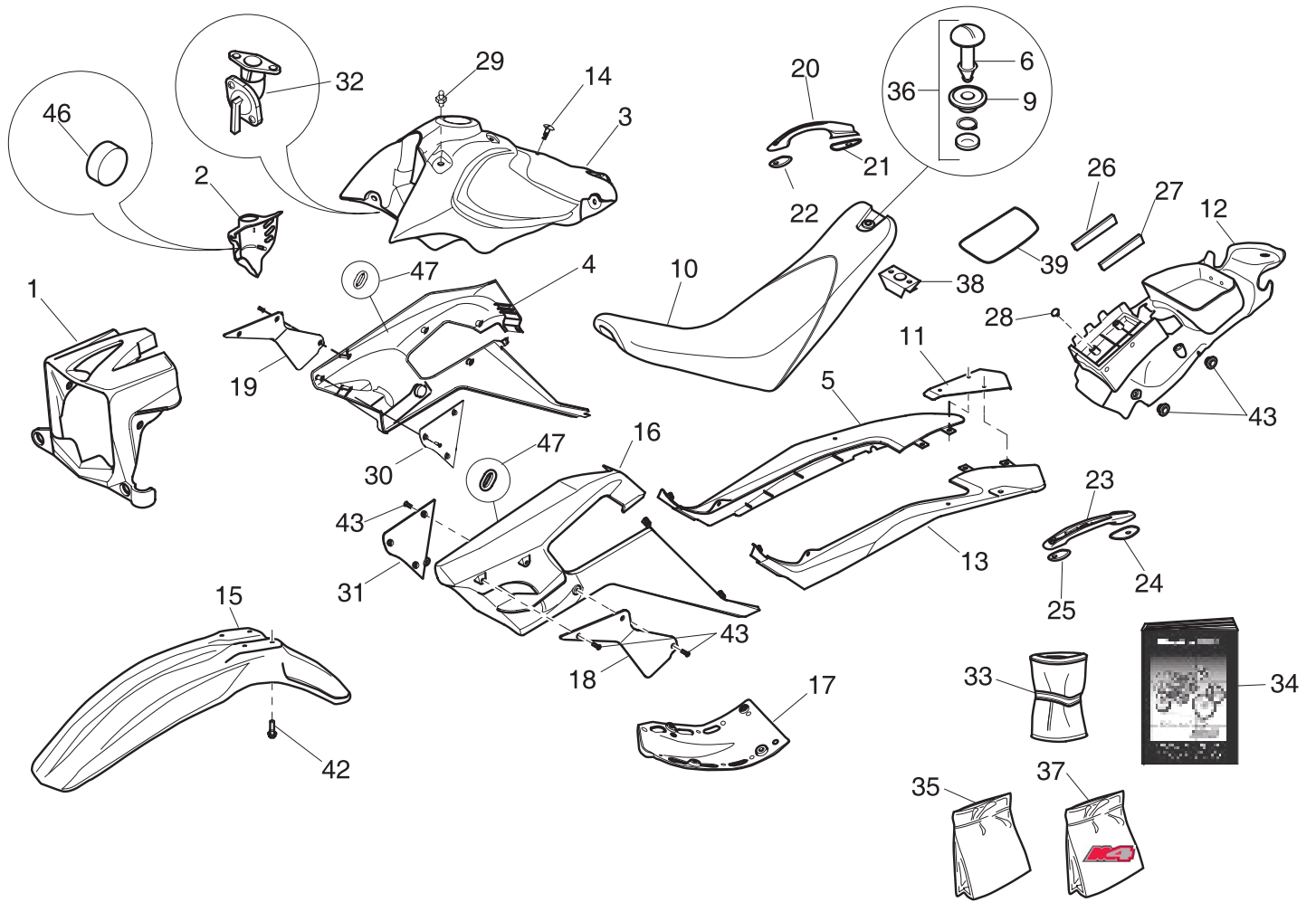

# Tav. 14a

Pos Loc Pos Ps Pos	Numero Number Numéro Número Nummer	Nota Note Note Nota Anm.	Descrizione	Description	Désignation	Beschreibung	Descripción
1	2228473 059		Mascherina p/faro	Light mask	Calandre phare	Scheinwerfermaske	Protección faro
2	2598675 059		Protezione commutatore	Switch protection	Protection contacteur	Schalterschutz	Protección conmutador
3	2806082 059		Serbatoio	Fuel tank	Réservoir	Benzintank	Depósito
4	1523204 OYY		Fianchetto serbatoio destro	Fuel tank right side	Cache latéral réservoir droit	Seitenverkleidung r.	Carenado tanque der.
5	1519864 OYY		Fiancata posteriore destra	Rear right side	Cache latéral arrière droit	Seitenverkleidung hinten rechte	Carenado tr. der.
6	2544070 000		Perno	Pivot	Pivot	Welle	Perno
9	2764597 000		Rondella	Washer	Rondelle	Unterlegscheibe	Arandela
10	2802656000		Sella	Saddle	Selle	Sitzbank	Sillin
11	1254350 OXX		Parafango post.	Rear mudguard	Garde-boue arrière	Hinterer Kotflügel	Guardabarros tras.
12	2524658 059		Passaruota	Wheelhouse	Passage roue	Radkasten	Pasa-rueda
13	1519865 OYY		Fiancata posteriore sinistra	Rear left side	Cache latéral arrière gauche	Seitenverkleidung hinten links	Carenado tr. izq.
14	3189010.000		Vite	Screw	Vis	Schraube	Tornillo
15	2515202 OYY		Parafango ant.	Front mudguard	Garde boue AV.	Vorderradkotflügel	Parte del. guardab.
16	1523205 OYY		Fianchetto serbatoio sinistro	Fuel tank left side	Cache latéral réservoir gauche	Seitenverkleidung l.	Carenado tanque der.
17	1232206 059		Carter parasassi	Gravel guard	Sabot de protection	Steinschlag Schutzgehäuse	Carter protector
18	1255873 4XX		Convogliatore fiancata sx	L.H. side manifold	Convoyeur cache latéral g.	Förderer links	Encalnalador izq.
19	1255872 4XX		Convogliatore fiancata dx	R.H. side manifold	Convoyeur cache latéral d.	Förderer rechts	Encalnalador der.
20	2200110 059		Maniglia passeggero dx	Right passenger grip	Poignée droite passager	Klinke für soz. r.	Manilla pasajero der.
21	1677608 000		Guarnizione maniglia post. dx	Rear right grip washer	Joint poignée arrière droite	Dichtung	Junta manilla tras. der.
22	1677606 000		Guarnizione maniglia ant. dx	Front right grip washer	Joint poignée avant droite	Dichtung	Junta manilla del. der.
23	2200111 059		Maniglia passeggero sx	Left passenger grip	Poignée gauche passager	Klinke für soz. l.	Manilla pasajero izq.
24	1677609 000		Guarnizione maniglia post. sx	Rear left grip washer	Joint poignée arrière gauche	Dichtung	Junta manilla del. izq.
25	1677607 000		Guarnizione maniglia ant. sx	Front left grip washer	Joint poignée avant gauche	Dichtung	Junta manilla del. izq.
26	2894951 000		Spugna batteria	Battery sponge	Eponge batterie	Gummi Batterie	Goma batería
27	2894952 000		Spugna batteria lato sx	Left side battery sponge	Eponge batterie côté gauche	Gummi Batterie, Links	Goma batería izq.
28	2910314 000		Tampone batteria	Battery buffer	Tampon batterie	Puffer batterie	Silent-block Bateria
29	2541840 000		Perno anc.fianc.serbatoio	Fuel tank side anch. pin	Axe anc. cache latéral réservoir	Zapfen für Anlenkung	Perno para eng.
30	1523212 159		Fianchetto int. serb. dx	Fuel tank int. right side	Cache latéral int. réservoir droit	Seitenverkleidung l., inner	Carenado tanque int. izq.
31	1523213 159		Fianchetto int. serb. sx	Fuel tank int. left side	Cache latéral int. réservoir gauche	Seitenverkleidung r., inner	Carenado tanque int. der.
32	2779602 000		Rubinetto benzina	Fuel cock	Robinet d'essence	Benzinhahn	Grifo gasolina
33	1105665 000		Borsetta con arnesi	Tool bag	Trousse à outils	Werkzeugtasche	Bolsa con útiles
34	2173283 100		Libretto istruzioni	Instruction manual	Livret d'instructions	Instruktionsbüchlein	Cuaderno instrucciones
35	1331447 500		Decalco per coperchi motore	Engine cover transfer	Décalcomanie pour couvercles moteur	Abziehbild Motordeckel	Calcomania tapa motor
36	2002043 000		Kit chiusura sella	Saddle clamp ki	Joue fermeture selle	Sitzbankverchluss	Kit cerradura sillin
37	1331464 059		Serie decalco (per veicolo nero)	Transfer set (for black vehicle)	Série décalco (pour véhicule noir)	Serie Aufkleber (für schwarz fahrz.)	Serie adhesivos (p. vehic. negro)
37	1331473 033		Serie decalco (per veicolo argento)	Transfer set (for silver vehicle)	Série décalco (pour véhicule argent)	Serie Aufkleber (für silber fahrz.)	Serie adhesivos (p. vehic. plata)
38	2731730 000		Ricettacolo	Receptacle	Réceptacle	Behälter	Receptáculo
39	1440045 000		Elastico fermabatteria	Battery elastic strap	Sangle batterie	Gummiband Batteriebefestigung	Elástico sujeta batería
42	1148025 000		Bullone 6.16 RS CH 8	6.16 RS CH 8 Bolt	Boulon 6.16 RS CH 8	Bolzen 6.16 RS CH 8	Perno 6.16 RS CH 8
43	3123370 000		Vite 4X11	Screw 4X11	Vis 4X11	Schraube 4X11	Tornillo 4X11
46	1638100 000		Gommino	Rubber	Rondelle	Gummi U-Scheibe	Goma
47	1634900 000		Gommino	Rubber	Rondelle	Gummi U-Scheibe	Goma

OYY	
059	Nero-Black-Noir-Schwarz-Negro
097	Rosso Fluo-Red Fluo-Rouge Fluo-Röt Fluo-Rojo Fluo



**Beta**  
the play bike

XX	
59	Per veicolo nero-for black vehicle-pour véhicule noir-für schwarz fahrz.-p. vehic. negro
00	Per veicolo argento-for silver vehicle-pour véhicule argent-für silber fahrz.-p. vehic. plata

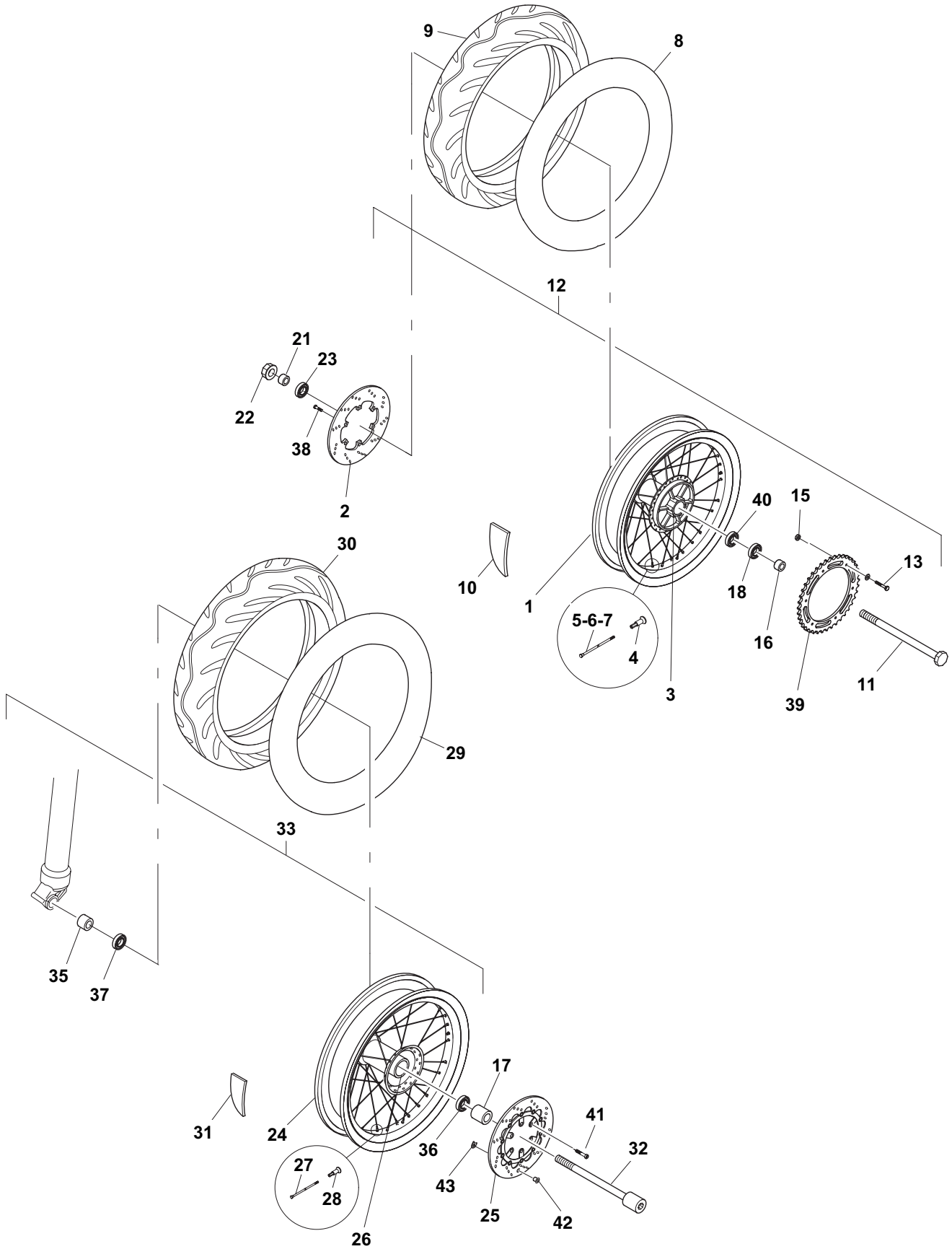

# Tav.15

Pos Loc Ps Pos	Numero Number Numéro Número Nummer	Nota Note Note Nota Anm.	Descrizione	Description	Désignation	Beschreibung	Descripció
1	1242938 000		Cerchio ruota post. 17"x4,25	17"x4,25 Rear wheel rim	Jante roue arrière 17"x4,25	Hinterradfelge 17"x4,25	Llanta rueda tras. 17"x4,25
2	1339575 000		Disco freno posteriore D. 220	Rear brake disk D. 220	Disque frein arrière D. 220	Hinterradbremsscheibe D. 220	Disco freno trasero D. 220
3	2208029 000		Mozzo posteriore	Rear hub	Moyeu arrière	Hinterradnabe	Cubo trasero
4	2310121 000		Nipples ruota D. 4	Wheel nipples D. 4	Roues nipples D. 4	Radnippel D. 4	Niples rueda D. 4
5	2725075 000		Raggio 4.00x174 ruota post. est. lato freno	4.00x174 rear wheel rad. ext. brake side	Rayon 4,00x174 roue arr. ext. Côté frein	Speiche 4.00 x 174	Rayo 4.00 174
6	2725076 000		Raggio 4.00x175 ruota post. int. lato freno	4.00x175 rear wheel rad. int. brake side	Rayon 4,00x175 roue arr. int. Côté frein	Speiche 4.00 x 175	Rayo 4.00 175
7	2725077 000		Raggio 4.00x174 ruota post. lato corona	4.00x174 rear wheel rad. crown side	Rayon 4,00x174 roue arr. côté couronne	Speiche 4.00 x 174	Rayo 4.00 174
8	1215002 000		Camera d'aria 4,25 x 17	4.25 x 17 air tube	Chambre à air 4,25 x 17	Luftschlauch 4,25 x 17	Cámara de aire 4,25 x 17
9	1281587 000		Copertura 150/60 - 17	150/60 - 17 tire	Revêtement 150/60 - 17	Reifen 150/60 - 17	Neumático 150/60 - 17
9	1281588 000		Copertura 150/60 - 17 Diablo	150/60 - 17 tire Diablo	Revêtement 150/60 - 17 Diablo	Reifen 150/60 - 17 Diablo	Neumático 150/60 - 17 Diablo
10	1538202 000		Flap 17.45	17.45 flap	flap 17.45	flap 17.45	flap 17.45
11	2555811 000		Perno ruota post.	Rear wheel pivot	Pivot roue	Hinterradachse	Perno rueda trasera
12	2704829 057		Ruota posteriore	Rear wheel	Roue arrière	Hinterrad	Rueda trasera
13	3163941 000		Vite M8x27 DACROMAT	Screw M8x27 DACROMAT	Vis M8x27 DACROMAT	Schraube M8x27 DACROMAT	Tornillo M8x27 DACROMAT
15	1317031 000		Dado M8 autobloccante	M8 self-locking nut	Ecrou auto-bloquant (M8)	Selbstsichernde Mutter M8	Tuerca de seguridad M8
16	1385517 000		Distanziale mozzo post. sx	Rear left hub spacer	Entretoise moyeu arrière gauche	Abstandhalter linke Hinterradnabe	Pasador cubo trasero izq.
17	1385513 000		Distanziale mozzo ant. sx	Front left hub spacer	Entretoise moyeu avant gauche	Abstandhalter Radnabe vorne links	Distanciadador cubo del. izq.
18	1299280 000		Cuscinetto 25.47.12	25.47.12 bearing	Palier 25.47.12	Lager 25.47.12	Rodamiento 25.47.12
21	1385515 000		Danziale mozzo post. dx	Rear right hub spacer	Entretoise moyeu arrière droit	Abstandhalter rechte Hinterradnabe	Pasador cubo trasero der.
22	1330330 000		Dado	Nut	Ecrou	Mutter	Tuerca
23	1299280 000		Cuscinetto 25.47.12	25.47.12 bearing	Palier 25.47.12	Lager 25.47.12	Rodamiento 25.47.12
24	1242937 000		Cerchio ruota ant. 17"x3,50-36	Front wheel rim 17"x3,50-36	Jante roue avant 17"x3,50-36	Vorderradfelge 17"x3,50-36	Llanta rueda del. 17"x3,50-36
25	1339581 000		Disco freno ant. D.310	Front brake disk D.310	Disque frein avant D.310	Vorderradbremsscheibe D.310	Disco freno del. D.310
26	2207253 000		Mozzo ant. con cuscinetti	Front hub with bearings	Moyeu avant avec roulement	Vorderradlager	Cubo del. Conjinete
27	2725071 000		Raggio 4.00x164 ruota ant. est. lato freno	4.00x164 front wheel rad. ext. brake side	Rayon 4,00x164 roue av. ext. côté frein	Speiche 4.00 x 164	Rayo 4.00 164
27	2725072 000		Raggio 4.00x167 ruota ant. int. lato freno	4.00x167 front wheel rad. int. brake side	Rayon 4,00x167 roue av. int. côté frein	Speiche 4.00 x 167	Rayo 4.00 167
27	2725073 000		Raggio 4.00x173 ruota ant. int. lato rinvio	4.00x173 front wheel rad. int. countershaft side	Rayon 4,00x173 roue av. int. côté renvoi	Speiche 4.00 x 173	Rayo 4.00 173
27	2725074 000		Raggio 4.00x170 ruota ant. est. lato rinvio	4.00x170 front wheel rad. ext. countershaft side	Rayon 4,00x170 roue av. ext. côté renvoi	Speiche 4.00 x 170	Rayo 4.00 170
28	2310121 000		Nipples ruota D.4	Wheel nipples D.4	Nipples roue D.4	Radnippel D.4	Niples rueda D.4
29	1218100 000		Camera d'aria ML 17	ML 17 air tube	Chambre à air ML 17	Luftschlauch ML 17	Cámara de aire ML 17
30	1281576 000		Copertura 120/70-17	120/70-17 tire	Revêtement 120/70-17	Reifen 120/70-17	Neumático 120/70-17
30	1281577 000		Copertura 120/70-17 Diablo	120/70-17 tire Diablo	Revêtement 120/70-17 Diablo	Reifen 120/70-17 Diablo	Neumático 120/70-17 Diablo
31	1538202 000		Flap 17.45	17.45 flap	flap 17.45	flap 17.45	flap 17.45
32	2555694 000		Perno ruota ant.	Front wheel pivot	Pivot roue avant	Vorderradachse.	Perno rueda del.
33	2702566 057		Ruota anteriore	Front wheel	Roue avant	Vorderrad	Rueda delantera
35	1385026 000		Distanziale mozzo ant. dx	Front right hub spacer	Entretoise moyeu avant droit	Abstandhalter Radnabe vorne rechts	Distanciadador cubo del. der.
36	1298502 000		Cuscinetto 20.47.14	20.47.14 bearing	Palier 20.47.14	Lager 20.47.14	Rodamiento 20.47.14
37	1298010 000		Cuscinetto 20.42.12	20.42.12 bearing	Palier 20.42.12	Lager 20.42.12	Rodamiento 20.42.12
38	3130605 000		Vite M6x16 UNI5933	Screw M6x16 UNI5933	Vis M6x16 UNI5933	Schraube M6x16 UNI5933	Tornillo M6x16 UNI5933
39	1289436 000		Corona Z. 42 5/8 1/4	Ring gear Z. 42 5/8 1/4	Couronne Z. 42 5/8 1/4	Zahnkranz Z. 42 5/8 1/4	Corona Z. 42 5/8 1/4
40	1299260 000		Cuscinetto 25.47.8	25.47.8 bearing	Palier 25.47.8	Lager 25.47.8	Rodamiento 25.47.8
41	3163922 000		Vite speciale M8x16 10.9 DACROMAT	Special screw M8x16 10.9 DACROMAT	Vis spéciale M8x16 10.9 DACROMAT	Spezialschraube M8x16 10.9 DACROMAT	Tornillo especial M8x16 10.9 DAC.
42	2211000 000		Magnete sensore Ø9	Sensor magneto Ø9	Magnéto capteur Ø9	Magnet Ø9	Magneto sensor Ø9
43	2822660 000		Anello seeger 9E	Clamp 9E	Clamp 9E	Seegering 9E	Anillo seeger 9E



# Tav.15a

Dal Nr. di telaio  
From frame nr.  
Du chassis  
Ab Rahmen  
Desde chasis

ZD3T2002180000129

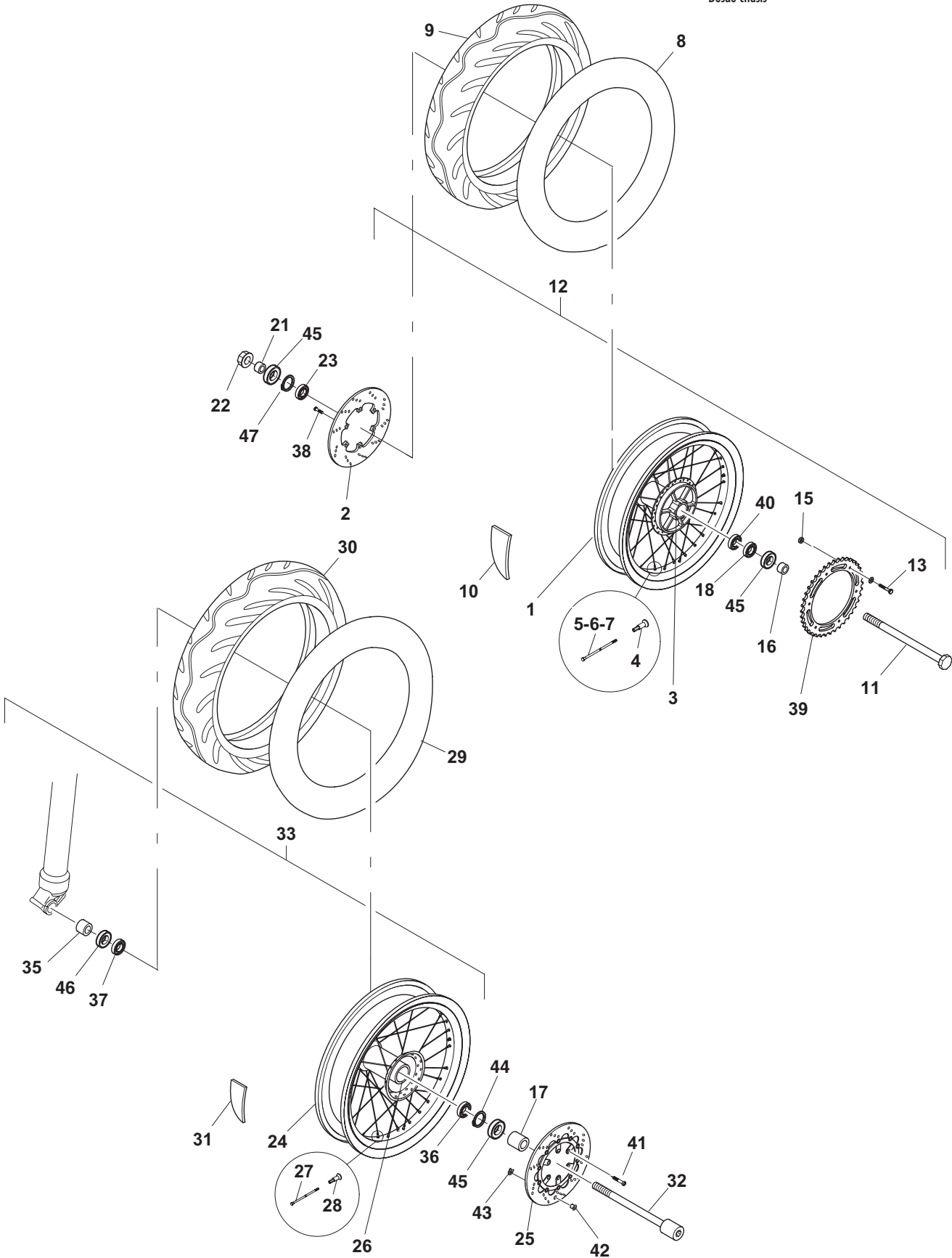

**Beta**  
the play bike

Dal Nr. di telaio

From frame nr.

Du chassis

Ab Rahmen

Desde chasis

## ZD3T2002180000129

Pos Loc Pos Ps Pos	Numero Number Número Nummer	Nota Note Nota Anm.	Descrizione	Description	Désignation	Beschreibung	Descripción
1	1242938 000		Cerchio ruota post. 17"x4,25	17"x4,25 Rear wheel rim	Jante roue arrière 17"x4,25	Hinterradfelge 17"x4,25	Llanta rueda tras. 17"x4,25
2	1339575 000		Disco freno posteriore D. 220	Rear brake disk D. 220	Disque frein arrière D. 220	Hinterradbremsscheibe D. 220	Disco freno trasero D. 220
3	2208053 000		Mozzo posteriore	Rear hub	Moyeu arrière	Hinterradnabe	Cubo trasero
4	2310121 000		Nipples ruota D. 4	Wheel nipples D. 4	Roues nipples D. 4	Radnippel D. 4	Niples rueda D. 4
5	2725075 000		Raggio 4.00x174 ruota post. est. lato freno	4.00x174 rear wheel rad. ext. brake side	Rayon 4,00x174 roue arr. ext. Côté frein	Speiche 4.00 x 174	Rayo 4.00 174
6	2725076 000		Raggio 4.00x175 ruota post. int. lato freno	4.00x175 rear wheel rad. int. brake side	Rayon 4,00x175 roue arr. int. Côté frein	Speiche 4.00 x 175	Rayo 4.00 175
7	2725077 000		Raggio 4.00x174 ruota post. lato corona	4.00x174 rear wheel rad. crown side	Rayon 4,00x174 roue arr. côté couronne	Speiche 4.00 x 174	Rayo 4.00 174
8	1215002 000		Camera d'aria 4,25 x 17	4.25 x 17 air tube	Chambre à air 4,25 x 17	Luftschlauch 4,25 x 17	Cámara de aire 4,25 x 17
9	1281587 000		Copertura 150/60 - 17	150/60 - 17 tire	Revêtement 150/60 - 17	Reifen 150/60 - 17	Neumático 150/60 - 17
9	1281588 000		Copertura 150/60 - 17 Diablo	150/60 - 17 tire Diablo	Revêtement 150/60 - 17 Diablo	Reifen 150/60 - 17 Diablo	Neumático 150/60 - 17 Diablo
10	1538202 000		Flap 17.45	17.45 flap	flap 17.45	flap 17.45	flap 17.45
11	2555811 000		Perno ruota post.	Rear wheel pivot	Pivot roue	Hinterradachse	Perno rueda trasera
12	2704857 057		Ruota posteriore	Rear wheel	Roue arrière	Hinterrad	Rueda trasera
13	3163941 000		Vite M8x27 DACROMAT	Screw M8x27 DACROMAT	Vis M8x27 DACROMAT	Schraube M8x27 DACROMAT	Tornillo M8x27 DACROMAT
15	1317031 000		Dado M8 autobloccante	M8 self-locking nut	Ecrou auto-bloquant (M8)	Selbstsichernde Mutter M8	Tuerca de seguridad M8
16	1385524 000		Distanziale mozzo post. sx	Rear left hub spacer	Entretoise moyeu arrière gauche	Abstandhalter linke Hinterradnabe	Pasador cubo trasero izq.
17	1385513 000		Distanziale mozzo ant. sx	Front left hub spacer	Entretoise moyeu avant gauche	Abstandhalter Radnabe vorne links	Distanciadador cubo del. izq.
18	1298285 000		Cuscinetto 25.47.12	25.47.12 bearing	Palier 25.47.12	Lager 25.47.12	Rodamiento 25.47.12
21	1385515 000		Distanziale mozzo post. dx	Rear right hub spacer	Entretoise moyeu arrière droit	Abstandhalter rechte Hinterradnabe	Pasador cubo trasero der.
22	1330330 000		Dado	Nut	Ecrou	Mutter	Tuerca
23	1298285 000		Cuscinetto 25.47.12	25.47.12 bearing	Palier 25.47.12	Lager 25.47.12	Rodamiento 25.47.12
24	1242937 000		Cerchio ruota ant. 17"x3,50-36	Front wheel rim 17"x3,50-36	Jante roue avant 17"x3,50-36	Vorderradfelge 17"x3,50-36	Llanta rueda del. 17"x3,50-36
25	1339581 000		Disco freno ant. D.310	Front brake disk D.310	Disque frein avant D.310	Vorderradbremsscheibe D.310	Disco freno del. D.310
26	2207253 000		Mozzo ant. con cuscinetti	Front hub with bearings	Moyeu avant avec roulement	Vorderradlager	Cubo del. Conjunte
27	2725071 000		Raggio 4.00x164 ruota ant. est. lato freno	4.00x164 front wheel rad. ext. brake side	Rayon 4,00x164 roue av. ext. côté frein	Speiche 4.00 x 164	Rayo 4.00 164
27	2725072 000		Raggio 4.00x167 ruota ant. int. lato freno	4.00x167 front wheel rad. int. brake side	Rayon 4,00x167 roue av. int. côté frein	Speiche 4.00 x 167	Rayo 4.00 167
27	2725073 000		Raggio 4.00x173 ruota ant. int. lato rinvio	4.00x173 front wheel rad. int. countershaft side	Rayon 4,00x173 roue av. int. côté renvoi	Speiche 4.00 x 173	Rayo 4.00 173
27	2725074 000		Raggio 4.00x170 ruota ant. est. lato rinvio	4.00x170 front wheel rad. ext. countershaft side	Rayon 4,00x170 roue av. ext. côté renvoi	Speiche 4.00 x 170	Rayo 4.00 170
28	2310121 000		Nipples ruota D.4	Wheel nipples D.4	Nipples roue D.4	Radnippel D.4	Niples rueda D.4
29	1218100 000		Camera d'aria ML 17	ML 17 air tube	Chambre à air ML 17	Luftschlauch ML 17	Cámara de aire ML 17
30	1281576 000		Copertura 120/70-17	120/70-17 tire	Revêtement 120/70-17	Reifen 120/70-17	Neumático 120/70-17
30	1281577 000		Copertura 120/70-17 Diablo	120/70-17 tire Diablo	Revêtement 120/70-17 Diablo	Reifen 120/70-17 Diablo	Neumático 120/70-17 Diablo
31	1538202 000		Flap 17.45	17.45 flap	flap 17.45	flap 17.45	flap 17.45
32	2555694 000		Perno ruota ant.	Front wheel pivot	Pivot roue avant	Vorderradachse.	Perno rueda del.
33	2702566 057		Ruota anteriore	Front wheel	Roue avant	Vorderrad	Rueda delantera
35	1385026 000		Distanziale mozzo ant. dx	Front right hub spacer	Entretoise moyeu avant droit	Abstandhalter Radnabe vorne rechts	Distanciadador cubo del. der.
36	1298505 000		Cuscinetto 20.47.14	20.47.14 bearing	Palier 20.47.14	Lager 20.47.14	Rodamiento 20.47.14
37	1298005 000		Cuscinetto 20.42.12	20.42.12 bearing	Palier 20.42.12	Lager 20.42.12	Rodamiento 20.42.12
38	3130605 000		Vite M6x16 UNI5933	Screw M6x16 UNI5933	Vis M6x16 UNI5933	Schraube M6x16 UNI5933	Tornillo M6x16 UNI5933
39	1289436 000		Corona Z. 42 5/8 1/4	Ring gear Z. 42 5/8 1/4	Couronne Z. 42 5/8 1/4	Zahnkranz Z. 42 5/8 1/4	Corona Z. 42 5/8 1/4
40	1298285 000		Cuscinetto 25.47.12	25.47.12 bearing	Palier 25.47.12	Lager 25.47.12	Rodamiento 25.47.8
41	3163922 000		Vite speciale M8x16 10.9 DACROMAT	Special screw M8x16 10.9 DACROMAT	Vis spéciale M8x16 10.9 DACROMAT	Spezialschraube M8x16 10.9 DACROMAT	Tornillo especial M8x16 10.9 DAC
42	2211000 000		Magnete sensore Ø9	Sensor magneto Ø9	Magneto capteur Ø9	Magnet Ø9	Magneto sensor Ø9
43	2822660 000		Anello seeger 9E	Circlip 9E	Circlip 9E	Seegerring 9E	Anillo seeger 9E
44	1067404 000		Anello di sicurezza	Snap ring	Circlip	Sicherungsring	Anillo de retención
45	1041336 000		Anello parapolvere 30x47x7	Dust cover 30x47x7	Disque pare-poussière 30x47x7	Staubdeckel 30x47x7	Disco guardapolvo 30x47x7
46	1041337 000		Anello parapolvere 30x50x7	Dust cover 30x50x7	Disque pare-poussière 30x50x7	Staubdeckel 30x50x7	Disco guardapolvo 30x50x7
47	1067403 000		Anello di sicurezza	Snap ring	Circlip	Sicherungsring	Anillo de retención

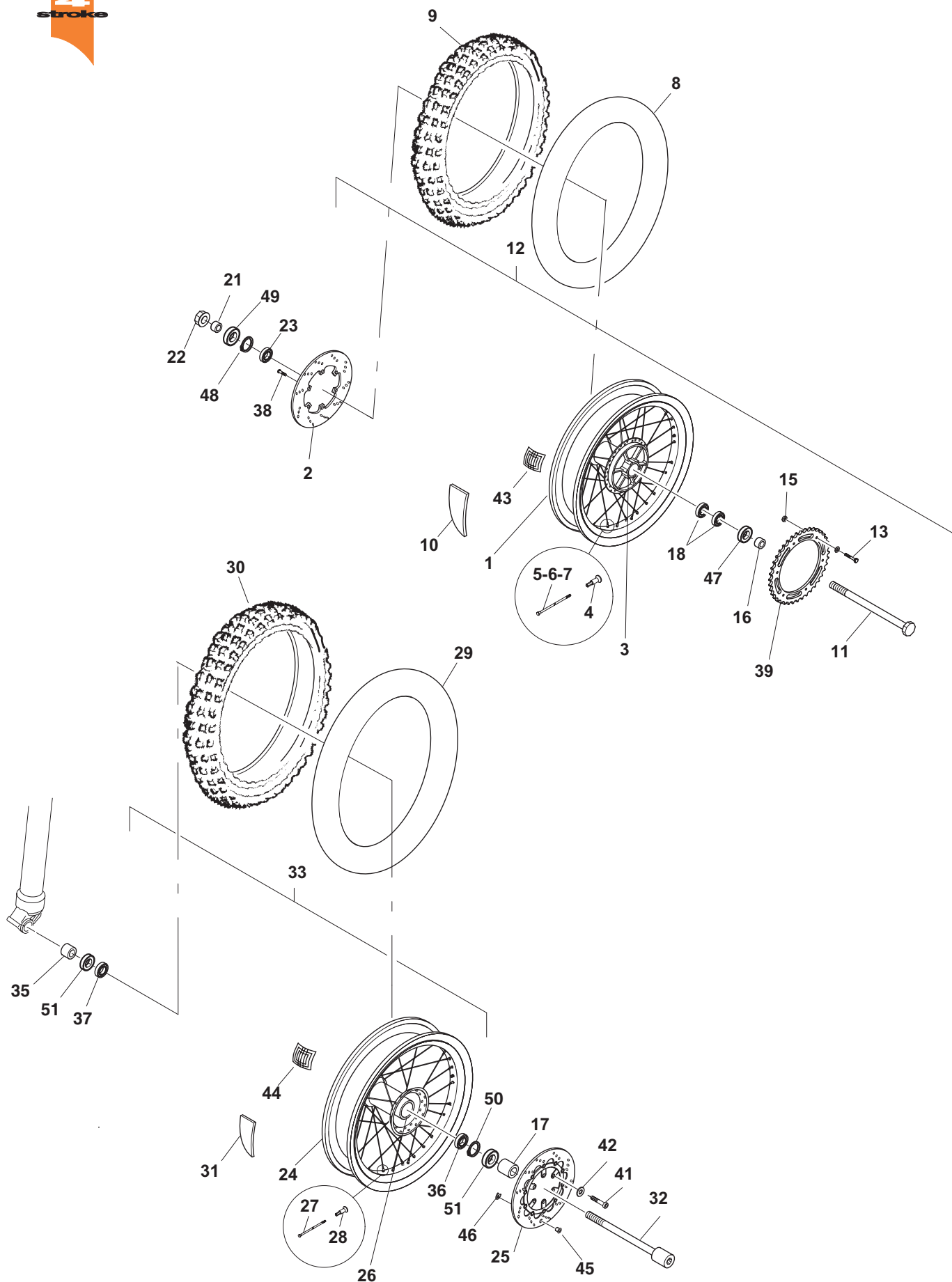



# Tav.16

Pos Loc Pos Ps Pos	Numero Number Número Número Nummer	Nota Note Note Nota Anm.	Descrizione	Description	Désignation	Beschreibung	Descripción
1	1242939 000		Cerchio ruota post.	Rear wheel rim	Jante roue arrière	Hinterradfelge	Llanta rueda tras.
2	1339573 000		Disco freno posteriore D. 220	Rear brake disk D. 220	Disque frein arrière D. 220	Hinterradbremsscheibe D. 220	Disco freno trasero D. 220
3	2208047 000		Mozzo posteriore	Rear hub	Moyeu arrière	Hinterradnabe	Cubo trasero
4	2310121 000		Nipples ruota D. 4	Wheel nipples D. 4	Roues nipples D. 4	Radnippel D. 4	Niples rueda D. 4
5	2725078 000		Raggio 4.00x187 ruota post. lato disco	4.00x187 rear wheel rad. disc side	Rayon 4,00x187 roue arr. côté disque	Speiche 4.00 x 187	Rayo 4.00 187
6	2725079 000		Raggio 4.00x184 ruota post. lato corona	4.00x184 rear wheel rad. crown side	Rayon 4,00x184 roue arr. côté couronne	Speiche 4.00 x 184	Rayo 4.00 184
8	1215004 000		Camera 2,20 . 18	2,20 . 18 air tube	Chambre à air 2,20 . 18	Luftschlauch 2,20 . 18	Cámara de aire 2,20 . 18
8	1216110 000	⊕	Camera	Air tube	Chambre à air	Luftschlauch	Cámara de aire
9	1281583 000		Copertura 140/80-18 70R M+S	140/80-18 70R M+S tire	Revêtement 140/80-18 70R M+S	Reifen 140/80-18 70R M+S	Neumático 140/80-18 70R M+S
9	1281582 000		Copertura 140/80-18 70S	140/80-18 70S tire	Revêtement 140/80-18 70S	Reifen 140/80-18 70S	Neumático 140/80-18 70S
9	1281591 000	⊕	Copertura 130/90-18 MT21	Tyre 130/90-18 MT21	Chape 130/90-18 MT21	Reifendecke 130/90-18 MT21	Cobertura 130/90-18 MT21
10	1536000 000		Flap ruota posteriore	Rear wheel flap	Flap roue arrière	Flap Hinterrad	Flap rueda trasera
11	2555811 000		Perno ruota post.	Rear wheel pivot	Pivot roue	Hinterradachse	Perno rueda trasera
12	2704856 457		Ruota posteriore	Rear wheel	Roue arrière	Hinterrad	Rueda trasera
12	2704868 457	⊕	Ruota posteriore	Rear wheel	Roue arrière	Hinterrad	Rueda trasera
13	3130605 000		Bullone 8 x 16 10.9	Bolt 8 x 16 10.9	Boulon 8 x 16 10.9	Bolzen 8 x 16 10.9	Perno 8 x 16 10.9
15	1317122 000		Dado M8 autobloccante	M8 self-locking nut	Ecrou auto-bloquant (M8)	Selbstsichernde Mutter M8	Tuerca de seguridad M8
16	1385028 000		Distanziale mozzo post. sx	Rear left hub spacer	Entretoise moyeu arrière gauche	Abstandhalter linke Hinterradnabe	Pasador cubo trasero izq.
17	1385026 000		Distanziale mozzo ant. sx	RH left hub spacer	Entretoise moyen AV. gauche	Abstandhalter Radnabe vorne links	Distanciadador cubo del. izq.
18	1298505 000		Cuscinetto 20.47.14	20.47.14 bearing	Palier 20.47.14	Lager 20.47.14	Rodamiento 20.47.14
21	1385027 000		Distanziale mozzo post. dx	Rear right hub spacer	Entretoise moyeu arrière droit	Abstandhalter rechte Hinterradnabe	Pasador cubo trasero der.
22	1330330 000		Dado	Nut	Ecrou	Mutter	Tuerca
23	1298005 000		Cuscinetto 20.42.12	20.42.12 bearing	Palier 20.42.12	Lager 20.42.12	Rodamiento 20.42.12
24	1242947 000		Cerchio ruota ant.	Front wheel rim	Jante roue avant	Vorderradfelge	Llanta rueda del.
25	1339579 000		Disco freno ant. D.260	Front brake disk D.260	Disque frein avant D.260	Vorderradbremsscheibe D.260	Disco freno del. D.260
26	2207252 000		Mozzo anteriore	Front hub	Moyeu avant	Vorderradnabe	Cubo del.
27	2725081 000		Raggio 4.00x230 ruota ant. interna	4.00x230 front wheel int.	Rayon 4,00x230 roue av. int.	Speiche 4.00 x 230	Rayo 4.00 230
27	2725082 000		Raggio 4.00x227 ruota post. est.	4.00x227 rear wheel rad. ext.	Rayon 4,00x227 roue arr. ext.	Speiche 4.00 x 227	Rayo 4.00 227
28	2310121 000		Nipples ruota D.4	Wheel nipples D.4	Nipples roue D.4	Radnippel D.4	Niples rueda D.4
29	1215003 000		Camera 1,85 . 21	1,85 . 21 air tube	Chambre à air 1,85 . 21	Luftschlauch 1,85 . 21	Cámara de aire 1,85 . 21
30	1281573 000		Copertura 90/90-21 54R (M+S)	Tyre 90/90-21 54R (M+S)	Chape 90/90-21 54R (M+S)	Reifendecke 90/90-21 54R (M+S)	Cobertura 90/90-21 54R (M+S)
30	1281572 000		Copertura 90/90-21 54S	Tyre 90/90-21 54S	Chape 90/90-21 54S	Reifendecke 90/90-21 54S	Cobertura 90/90-21 54S
30	1279135 000	⊕	Copertura 90/90-21 MT21	Tyre 130/90-18 MT21	Chape 130/90-18 MT21	Reifendecke 130/90-18 MT21	Cobertura 130/90-18 MT21
31	1538200 000		Flap ruota anteriore	Front wheel flap	Flap roue avant	flap Vorderrad	flap delantera
32	2555694 000		Perno ruota ant.	Front wheel pivot	Pivot roue avant	Vorderradachse.	Perno rueda del.
33	2702594 457		Ruota anteriore	Front wheel	Roue avant	Vorderrad	Rueda delantera
33	2702607 457	⊕	Ruota anteriore	Front wheel	Roue avant	Vorderrad	Rueda delantera
35	1385523 000		Distanziale mozzo ant. dx	Front right hub spacer	Entretoise moyeu avant droit	Abstandhalter Radnabe vorne rechts	Distanciadador cubo del. der.
36	1298005 000		Cuscinetto 20.42.12	20.42.12 bearing	Palier 20.42.12	Lager 20.42.12	Rodamiento 20.42.12
37	1298005 000		Cuscinetto 20.42.12	20.42.12 bearing	Palier 20.42.12	Lager 20.42.12	Rodamiento 20.42.12
38	3130605 000		Vite M6x16 UNI 5933	Screw M6x16 UNI 5933	Vis M6x16 UNI 5933	Schraube M6x16 UNI 5933	Tornillo M6x16 UNI 5933
39	1289482 000		Corona Z. 48 5/8 1/4	Ring gear Z. 48 5/8 1/4	Couronne Z. 48 5/8 1/4	Zahnkranz Z. 48 5/8 1/4	Corona Z. 48 5/8 1/4
41	1147101 000		Bullone M6x14 ch8 10.9	Bolt M6x14 ch8 10.9	Boulon M6x14 ch8 10.9	Bolzen M6x14 ch8 10.9	Perno M6x14 ch8 10.9
42	2739400 000		Rondella M6	Washer m6	Rondelle m6	Unterlegscheibe m6	Arandela m6
43	1517530 000		Ferma fascione per cerchio	Hubcap ring block	Plaquette de blocage pour jante	Felgenhalterung	Sujeta cibrtura
44	1517550 000		Ferma fascione per cerchio	Hubcap ring block	Plaquette de blocage pour jante	Felgenhalterung	Sujeta cibrtura
45	2211000 000		Magnete sensore Ø9	Sensor magneto Ø9	Magnéto capteur Ø9	Magnet Ø9	Magneto sensor Ø9
46	2822660 000		Anello seeger 9E	Circlip 9E	Circlip 9E	Seegerring 9E	Anillo seeger 9E
47	1041336 000		Anello parapolvere 30x47x7	Dust cover 30x47x7	Disque pare-poussière 30x47x7	Staubdeckel 30x47x7	Disco guardapolvo 30x47x7
48	1067409 000		Anello di sicurezza	Snap ring	Circlip	Sicherungsring	Anillo de retención
49	1041335 000		Anello parapolvere	Dust cover	Disque pare-poussière 30x50x7	Staubdeckel 30x50x7	Disco guardapolvo 30x50x7
50	1067409 000		Anello di sicurezza	Snap ring	Circlip	Sicherungsring	Anillo de retención
51	1041335 000		Anello parapolvere	Dust cover	Disque pare-poussière 30x50x7	Staubdeckel 30x50x7	Disco guardapolvo 30x50x7

⊕ Coperture opzionali, montate solo su veicoli a partire dal telaio Nr. ZD3T2002080000415  
 Optional tyres, employed only on vehicles from frame Nr. ZD3T2002080000415  
 Pneus optionnels, montés seulement sur les véhicules à partir du chassis ZD3T2002080000415  
 Optional reifen, zugetroffen nur auf fahrzeuge von der rahmennummer ZD3T2002080000415  
 Coberturas opcionales, empleado solamente en los vehiculos desde nr. ZD3T2002080000415



**Beta**  
the play bike

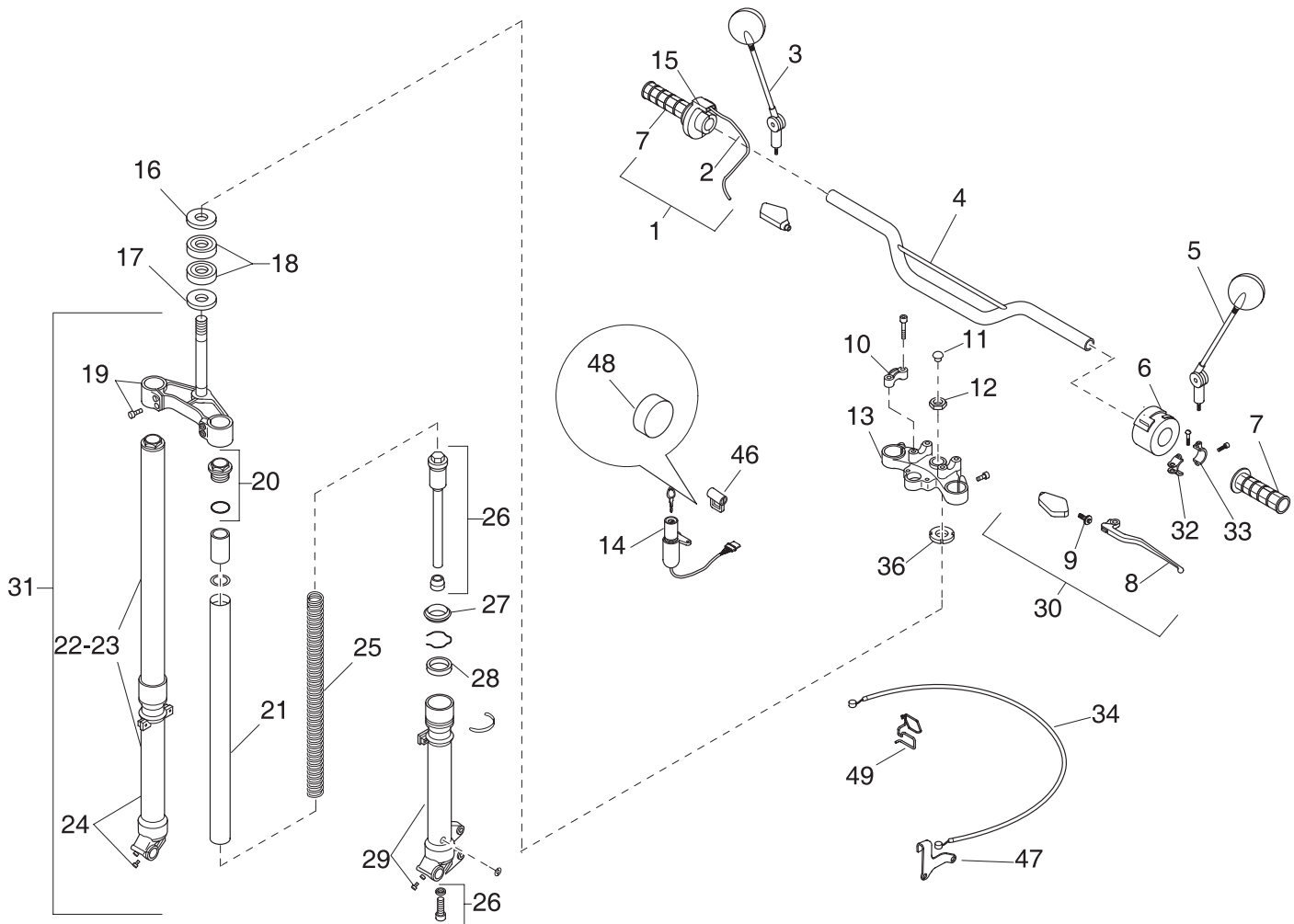

# Tav.17

Pos Loc Pos Ps Pos	Numero Number Numéro Número Nummer	Nota Note Note Nota Anm.	Descrizione	Description	Désignation	Beschreibung	Descripción
1	1255096 000		Comando gas con manopole	Throttle control with grip	Comm. Gaz avec poignée	Gasdrehgriff	Transmisión
2	2915187 000		Trasmissione gas	Throttle transmission	Transmission gaz	Gaszug	Transmisión gas
3	2892927 000		Specchietto retrovisore dx	RH rearview mirror	Rétroviseur D.	Rückspiegel rechts	Espejo retrovisor derecho
4	2220384 033		Manubrio	Handlebars	Guidon	Lenker	Manillar
5	2892925 000		Specchietto retrovisore sx	LH rearview mirror	Rétroviseur G.	Rückspiegel links	Espejo retrovisor izquierdo
6	1306507 000		Dispositivo sx con fili	LH device with wires	Dispositif G. avec fils	Linkes Bedienungselement mit Kabeln	Dispositivo izq. con cable
7	2218532 000		Manopole (coppia)	Handgrips (pair)	Poignées (paire)	Handgriffe (Paar)	Empuñadura ( juego )
8	2127086 000		Leva frizione nuda	Clutch lever	Levier embrayage nu	Kupplungshebel	Palanca embrague
9	2726063 000		Registro leva frizione	Clutch lever adjuster	Réglage embrayage	Einstellvorrichtung Kupplungshebel	Regulador palanca embrague
10	1208250 000		Morseetto	Clamp	Etau	Schelle	Brida
11	2901856 000		Tappo canotto	Tube cap	Bouchon tube	Verschluß Lenkerkopffrohr	Tapa tubo pivote
12	1330960 000		Dado canotto	Head tube nut	Ecrou colonne	Lenkrohrmutter	Tuerca
13	2950195 057		Testata forcella	Fork head	Té supérieur	Gabelkopf	Cabeza horquilla
14	1647303 000		Gruppo serrature	Locking group	Groupe serrures	Schloßsatz	Grupo cerraduras
15	1306510 000		Dispositivo dx con fili	RH device with wires	Dispositif D. avec fils	Rechtes Bedienungselement mit Kabeln	Dispositivo der. con cables
16	2598781 000		Protez. cuscinetti superiore	Upper bearing protection	Protection roulement sup.	Obere Lagerabdeckung	Protección cojinetes superiores
17	2598751 000		Protez. cuscinetti inferiore	Lower bearing protection	Protection roulement inf.	Untere Lagerabdeckung	Protección cojinetes inferiores
18	1299300 000		Cuscinetto	Bearing	Roulement	Lager	Cojinete
19	1209749 057		Crociera c/canotto forcella	Cross piece with fork head tube	Té inférieur	Kreuz mit Gabelrohr	Cruceta c/ tubo horquilla
20	2901878 000		Tappo con anello	Plug with ring	Bouchon avec bague	Verschluß mit Ring	Tapón con anillo
21	2940461 000		Tubo completo ambidx	LH-RH tube assembly	Tube D. complet	Rohr komplett rechts	Tubo completo
22	1601008 000	M4	Gamba sx completa	l.h. leg assembly	Bras G. complet	Linkes Bein komplett	Pata izquierda completa
22	1601006 000	Alp 4.0	Gamba sx completa	l.h. leg assembly	Bras G. complet	Linkes Bein komplett	Pata izquierda completa
23	1601007 000	M4	Gamba dx completa	r.h.leg assembly	Bras D. complet	Rechtes Bein komplett	Pata derecha completa
23	1601005 000	Alp 4.0	Gamba dx completa	r.h.leg assembly	Bras D. complet	Rechtes Bein komplett	Pata derecha completa
24	1618661 059	M4	Gamba dx	RH leg	Fourreau D.	Gabelbein rechts	Barra der.
24	1618662 057	Alp 4.0	Gamba dx	RH leg	Fourreau D.	Gabelbein rechts	Barra der.
25	2252784 000		Molla	Spring	Ressort	Feder	Muelle
26	1232988 000	M4	Cartuccia meccanica	Mechanical cartridge	Cartouche amort.	Mechanische Hülle	Cartucho mecánico
26	1232989 000	Alp 4.0	Cartuccia meccanica	Mechanical cartridge	Cartouche amort.	Mechanische Hülle	Cartucho mecánico
27	1041473 000		Anello parapolvere	Dust cover ring	Joint poussière	Staubschuttring	Anillo guardapolvo
28	1067526 000		Anello tenuta	Seal ring	Joint d'étanchéité	Dichtungsring	Retenedor de aceite
29	1618385 059	M4	Gamba sx	LH leg	Fourreau G.	Gabelbein links	Barra izquierda
29	1618386 057	Alp 4.0	Gamba sx	LH leg	Fourreau G.	Gabelbein links	Barra izquierda
30	2102429 000		Leva com. friz. compl.	Clutch lever assembly	Levier embrayage complet	Kupplungshebel komplett	Palanca mando embrague completa
31	1508035 000	Alp 4.0	Forcella	Fork	Fourche	Gabel	Horquilla
31	1508034 059	M4	Forcella	Fork	Fourche	Gabel	Horquilla
32	2898405 000		Supporto portaleva	Lever holder bracket	Support porte levier	Hebelauflage Halter	Soporte porta-palanca
33	1255005 000		Collarino	Clamp	Collier	Schelle	Collar
34	2914595 000	Alp 4.0	Trasmissione frizione	Clutch cable	Transmission embrayage	Kupplungsseil	Transmisión embrague
34	2914597 000	M4	Trasmissione frizione	Clutch cable	Transmission embrayage	Kupplungsseil	Transmisión embrague
36	1620632 000		Ghiera di registro	Register ring nut	Bague de réglage	Gewinding	Casquillo
46	2885850 000		Serratura porta casco	Helmet lock	Serrure casque	Schloß Helmhalter	Cerradura portacasco
47	1091200 000		Attacco capocorda trasm. frizione	Clutch transmission lug connector	Fixation extrémité transm. Embrayage	Befestigung kabelende	Anclaje terminal
48	1638100 000		Gommino	Rubber	Caoutchouc	Gummi U-Scheibe	Goma
49	2524462 000	M4	Passacavo trasmissione frizione	Grommet clutch cable	Passe-câble transmission embrayage	Kabeldurchgang Kupplungsseil	Pasacables transmisión embrague

# Tav.18

ALP40

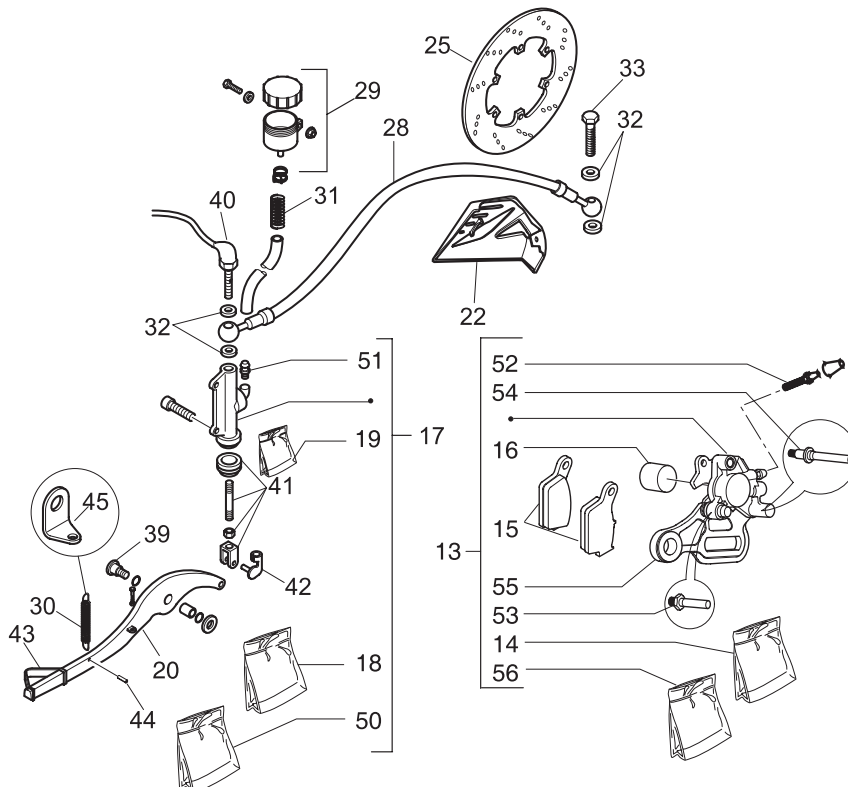
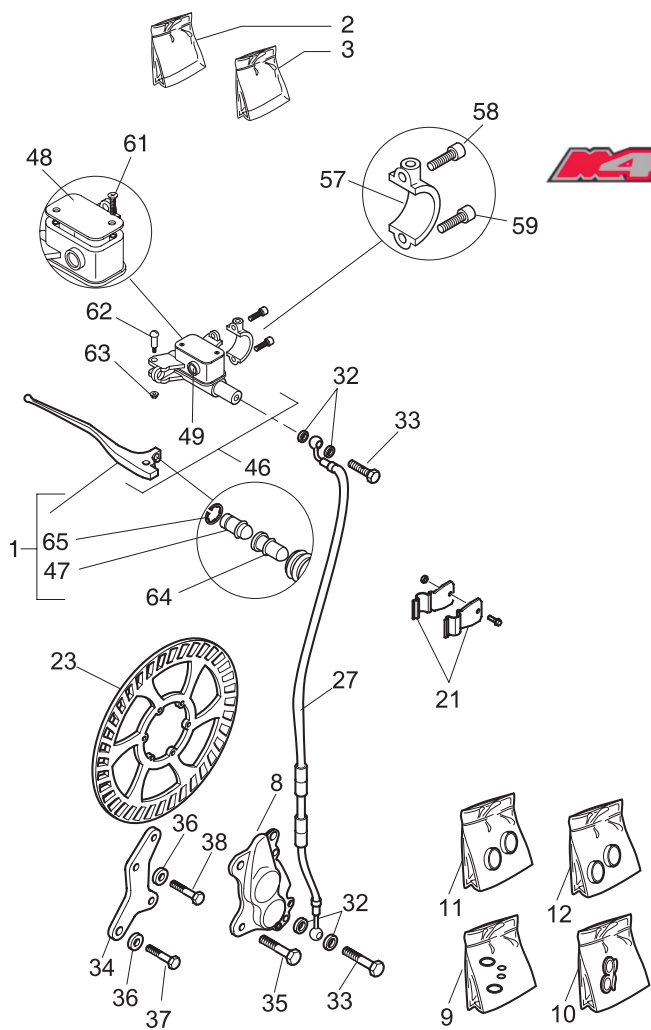
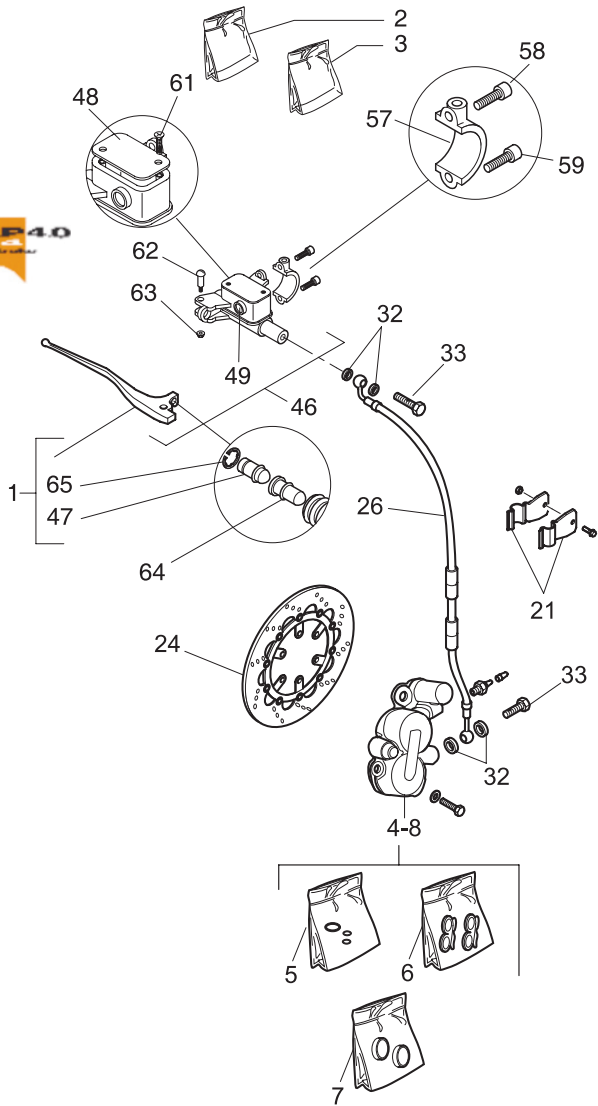

# Tav.18

Pos Loc Pos Ps Pos	Numero Number Numéro Número Nummer	Nota Note Note Nota Anm.	Descrizione	Description	Désignation	Beschreibung	Descripción
1	2127106 000		Leva freno ant. nuda	Front brake lever	Levier frein AV. nu	Bremshebel Vorderradbremse	Palanca freno delantera
2	2008274 000		Kit revisione pompa	Kit for master cyl. overhauling	Kit rév. maître cyl.	Reparatursatz Hauptbremszylinder	Kit revisión bomba
3	2005064 000		Kit pistoncino pompa ant.	Piston kit front master cyl.	Kit piston. maître cyl. AV.	Kolbensatz vorderhauptbremszylinder	Kit piston bomba del.
4	2503049 000	Alp 4.0	Pinza freno a disco ant.	Front disc brake caliper	Etrier frein AV.	Bremsattel an vorderer Scheibenbremse	Pinza freno disco delantera
5	2002708 000	Alp 4.0	Kit guarnizioni	Washer kit	Kit joints	Dichtungensatz	Grupo juntas
6	2525244 000	Alp 4.0	Pastiglie	Pads	Plaquettes	Bremzange	Juego past. frenos
7	2569445 000	Alp 4.0	Pistone Ø 28	Ø 28 piston	Piston Ø 28	Kolben Ø 28	Pistón Ø 28
8	2503061 000	M4	Pinza freno a disco ant.	Front disc brake caliper	Etrier frein AV.	Bremsattel an vorderer Scheibenbremse	Pinza freno disco delantera
9	2002709 000	M4	Kit guarnizioni	Washer kit	Kit joints	Dichtungensatz	Grupo juntas
10	2525246 000	M4	Pastiglie	Pads	Plaquettes	Bremzange	Juego past. frenos
11	2569447 000	M4	Pistone Ø 22	Ø 22 piston	Piston Ø 22	Kolben Ø 22	Pistón Ø 22
12	2569448 000	M4	Pistone Ø 25	Ø 25 piston	Piston Ø 25	Kolben Ø 25	Pistón Ø 25
13	2503067 000		Pinza freno a disco post.	Rear disc brake caliper	Etrier frein AR.	Bremsattel an hinterer Scheibenbremse	Pinza freno de disco trasera
14	2008272 000		Kit guarnizione pinza	Clip washer kit	Kit joint étrier	Dichtungensatz Hauptbremszange	Grupo juntas pinza
15	2525345 000		Pastiglie x pinza	Clip pads	Plaquettes pour étrier	Bremsbelag	Pastillas pinza
16	2569459 000		Pistone Ø 30	Ø 30 piston	Piston Ø 30	Kolben Ø 30	Pistón Ø 30
17	2591177 000		Pompa freno post.	Rear brake pump	Maître-cylindre frein AR.	Bremspumpe Hinterradbremse	Bomba freno trasero
18	2002707 000		Kit guarnizioni	Washer kit	Kit joints	Dichtungensatz	Grupo juntas
19	2569456 000		Pistone Ø 12	Ø 12 piston	Piston Ø 12	Kolben Ø 12	Pistón Ø 12
20	2528085 000		Pedale freno	Brake pedal	Pédale frein	Bremspedal	Pedal freno
21	2559626 000		Piastrina fis. tubo freno ant.	Front brake tube fix. plate	Plaquette de fixation tube frein avant	Befestigungsblech Vordere Bremsleitung	Placa sujeción tubo freno del.
22	2598785 059		Protezione pinza fr. post.	Rear brake clip protection	Protection étrier frein arrière	Schutz Bremszange	Protección pinza freno tras.
23	1339581 000	M4	Disco freno ant. D.310.	Front brake disk D.310.	Disque frein avant D.310.	Vorderradbrems Scheibe D.310.	Disco freno del. D.310.
24	1339579 000	Alp 4.0	Disco freno anteriore D.260.	Rear brake disk D.260.	Disque frein arrière D.260.	Hinterradbrems Scheibe D.260.	Disco freno trasero D.260.
25	1339573 000		Disco freno posteriore D.220.	Rear brake disk D.220.	Disque frein arrière D.220.	Hinterradbrems Scheibe D.220.	Disco freno trasero D.220.
26	2909128 000	Alp 4.0	Tubo freno a disco ant.	Front disc brake line	Canalisation frein AV.	Bremsleitung zur vorderen Scheibenbremse	Tubo freno de disco delantero
27	2909105 000	M4	Tubo freno a disco ant.	Front disc brake line	Canalisation frein AV.	Bremsleitung zur vorderen Scheibenbremse	Tubo freno de disco delantero
28	2909133 000		Tubo freno a disco post.	Rear disc brake line	Canalisation frein AR.	Bremsleitung zur hinteren Scheibenbremse	Tubo freno de disco trasero
29	2805100 000		Serbatoio olio freni	Brake fluid reservoir	Réservoir liquide frein	Bremsflüssigkeitsbehälter	Tanque liquido frenos
30	2248810 000		Molla ritorno ped. freno end	Brake pedal return spring	Ressort retour plate-forme frein enduro	Molla ritorno ped.freno end	Molla ritorno ped.freno end
31	2255535 000		Molla prot. tubo freno	Brake tube protection spring	Ressort protect. tube frein	Feder	Muelle
32	1650510 000		Rondella rame	Rove	Rondelle cuivre	Kupfer U.Scheibe	Arandela de cobre
33	1165040 000		Bullone M10 x 100	M10 x 100 bolt	Boulon M10 x 100	Schraubbolzen M10 x 100	Tornillo M10 x 100
34	2894555 000	M4	Piastra ancoraggio pinza anteriore	Front clip anchorage	Pince ancrage étrier avant	Befestigungsblech vorderbremszange	palanca sujeción palanca freno del.
35	1154490 000	M4	Bullone 8 x 20	8 x 20 bolt	Boulon 8 x 20	Schraubbolzen 8 x 20	Tornillo 8 x 20
36	2756055 000	M4	Rondella zigrinata Ø 8	Ø 8 milled washer	Rondelle cannelée Ø 8	Rändelscheibe Ø 8	Arandela moleada Ø 8
37	1155470 000	M4	Bullone 8 x 35	8 x 35 bolt	Boulon 8 x 35	Schraubbolzen 8 x 35	Tornillo 8 x 35
38	1155900 000	M4	Bullone 8 x 55	8 x 55 bolt	Boulon 8 x 55	Schraubbolzen 8 x 55	Tornillo 8 x 55
39	1164601 000		Bullone spec. ped. freno	Special brake pedal bolt	Boulon spéc. plate-forme frein	Spezialschraube	Tornillo especial
40	1889622 000		Interruttore stop freno post.	Rear brake stop switch	Interrupteur stop frein arrière	Stopschalter Hinterradbremse	Interruptor stop freno tras.
41	1084092 000		Asta comando pompa freno	Brake pump command rod	Tige de commande pompe frein	Stange Hauptbremszylinder	Varilla mando bomba freno
42	2893130 000		Staffa bloccaggio asta	Rod blocking clamp	Bride de blocage tige	Stangebefestigung	Brida fijación varilla
43	2290051 000		Mozzetto c/pedana	Hub with footboard	Moyeu avec plate-forme	Nabe mit Fußblech	Cubo con estribo
44	2893145 000		Spina elastica 3,4	3,4 flexible pin	Goujon élastique 3,4	Feder 3,4	Pasador elástico 3,4
45	2557912 000		Piastrina fis. leva ped. freno	Brake pedal lever fix. plate	Plaquette de fixation levier plate-forme frein	Befestigungsblech Bremshebel	Placa sujeción palanca freno
46	2102059 000	Alp 4.0	Leva com. freno ant. c/pompa	Front brake command lever w/ pump	Levier de frein avant avec pompe	Bremslichtschalter Vorderradbremse	Empaque de cobre
46	2102067 000	M4	Leva com. freno ant. c/pompa	Front brake command lever w/ pump	Levier de frein avant avec pompe	Bremslichtschalter Vorderradbremse	Empaque de cobre
47	2541873 000		Puntalino	Push piece	Pièce de pression	Druckst. ck	Varilla de presión
48	1268110 000		Coperchio pompa	Pump cover	Couvercle pompe	Pumpendeckel	Tapa bomba
49	2910281 000		Oblò ispezione livello olio	Oil level sight glass	Hublot d'inspection niveau huile	Ölkontrollschauglas	Visor de inspección nivel aceite
50	2008268 000		Kit revisione pompa	Kit for master cyl. overhauling	Kit rév. maître cyl.	Reparatursatz Hauptbremszylinder	Kit revisión bomba
51	2723421 000		Raccordo pompa freno post.	Brake fluid reservoir	Raccord maître-cylindre AR.	Anschluß Bremspumpe Hinterradbremse	Tanque aceite freno
52	3196801 000		Vite spurgo	Bleeder	Vis de purge	Entlüftungsschraube	Tornillo de espurgo
53	2541854 000		Perno ancoraggio Ø8	Anchor pin Ø8	Pivot d'ancrage Ø8	Befestigungszapfen Ø8	Perno anclaje Ø8
54	2541856 000		Perno ancoraggio Ø9	Anchor pin Ø9	Pivot d'ancrage Ø9	Befestigungszapfen Ø9	Perno anclaje Ø9
55	2898121 000		Piastra portapinza	Caliper holder plate	Plaque porte-pince	Bremszangenplatte	L-mina porta-pinza
56	2008273 000		Kit viti/supporto molla	Kit screws/Spring support	Jeu vis/Support ressort	Schraubensatz/Federhalter	Kit tornillos/Soporte muelle
57	1230103 000		Cappellotto con bussola fiss. specchietto	Cap with socket wing mirror fixing screw	Capuchon à douille fixation rétroviseur	Sicherungskappe	Capuchon bloqué
58	3196808 000		Vite fissaggio cappellotto	Cap fixing screw	Vis de fixation capuchon	Schraube	Tornillo fijación capuchón
59	3196809 000		Vite fissaggio cappellotto	Cap fixing screw	Vis de fixation capuchon	Schraube	Tornillo fijación capuchón
61	3196810 000		Vite coperchio serbatoio	Fuel tank cover screw	Vis couvercle réservoir	Schraube tankdeckel	Tornillo tapa tanque
62	3196818 000		Vite fissaggio leva	Lever fixing screw	Vis de fixation levier	Schraube	Tornillo fij. palanca
63	1311510 000		Dado	Nut	Ecrou	Mutter	Tuerca
64	2541858 000	M4	Puntalino	Push piece	Pièce de pression	Druckst. ck	Varilla de presión
64	2541874 000	Alp 4.0	Puntalino	Push piece	Pièce de pression	Druckst. ck	Varilla de presión
65	2822550 000		Seeger RA4	Seeger RA4	Seeger RA4	Seeger RA4	Seeger RA4

# Tav.19

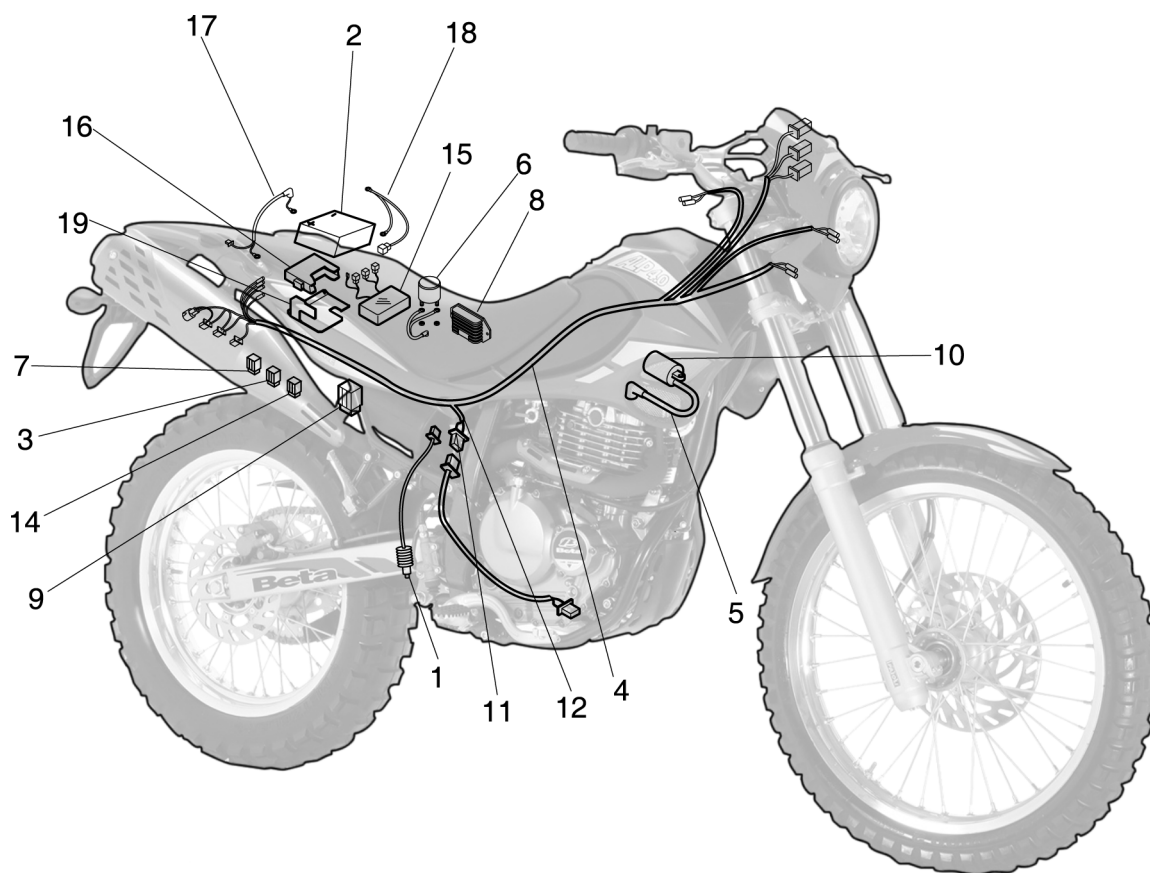

Pos Loc Pos Ps Pos	Numero Number Numéro Número Nummer	Nota Note Note Nota Anm.	Descrizione	Description	Désignation	Beschreibung	Descripción
1	1889620 000		Interruttore stop con cabl. freno post.	Rear brake cable stop switch	Interrupteur stop avec câble frein arr.	Stopschalter Hinterradbremse mit kabel	Interruptor stop freno tras. con cable
2	1115420 000		Batteria tipo F7 12B ecoforce 12V	F7 12B ecoforce 12V battery	Batterie type F7 12B ecoforce 12V	Wartungsfreie Batterie F7 12B ecoforce 12 V	Bateria Hermética F7 12B ecoforce 12V
3	2591776 000		Portafusibili c/fusib. motore 350cc	350cc engine fuse holder with fuses	Porte-fusibles avec fusibles moteur 350 cm3	Sicherungshalter mit Sicherungen	Portafusible con fusible
4	1801617 000		Impianto elettrico centrale	Central electrical system	Circuit électrique central	Elektroverkabelung	Cableado eléctrico
5	2713552 000		Raccordo candela schermato motore 350cc	350cc engine shielded sparkplug joint	Raccord de bougie blindé moteur 350 cm3	Zündkerzenstecker	Conexión bujía
6	2728469 000		Relè' avviamento	Starting relay	Relais du démarreur	Anlasserrelais	Relè de arranque
7	2728466 000		Relè cavalletto	Stand relay	Relais béquille	Relais Ständer	Relè caballette
8	2728097 000		Regolatore motore 350cc	350cc engine regulator	Régulateur moteur 350 cm3	Regler	Regulador
9	1336100 000		Dispositivo ritardo spia carburante	Fuel indicator delay mechanism	Dispositif retard témoin de carburant	Verzögerungs vorrichtung Benzinstand-Kontrollleuchte	Dispositivo atraso luz testigo carburante
10	1120698 000		Bobina	Coil	Bobine	Spule	Bobina
11	1255361 000		Connettore impianto	System connector	Connecteur circuit	Kabelverbinder	Conector instalación
12	2911976 000		Terminale impianto	Terminals system	Terminal circuit	Kabelschuh	Terminal instalación
14	1884946 000		Intermittenza	Intermittence	Intermittence	Blinkgeber	Intermittencia
15	1241843 000		Centralina elettronica	Control unit	Centrale	Steuergehäuse	Centralita
16	2897895 000		Supporto in gomma centralina	Rubber control unit support	Support en caoutchouc centrale	Haltebügel für elektronisches Steuergerät	Soporte centralita electrónica
17	1801524 000		Impianto relè avviamento motorino avviamento	Ignition relay system Starter motor ignition	Circuit relais démarrage Démarreur	Anlasserrelais Startermotor	Relè arranque Motor de arranque
18	1801522 000		Impianto batteria relè avviamento	Ignition relay battery system	Circuit batterie relais démarrage	Kabelstrang Batterierelais	Circuito relè batteria
19	2557679 000		Piastra sup. gomma centralina	Control unit rubber top plate	Plaque supp. Rondelle centrale	Befestigung für elektronisches Steuergerät	Chapa soporte centralita electrónica



**Beta**  
the play bike