

IGNITION SYSTEM

SYSTEM DIAGRAM

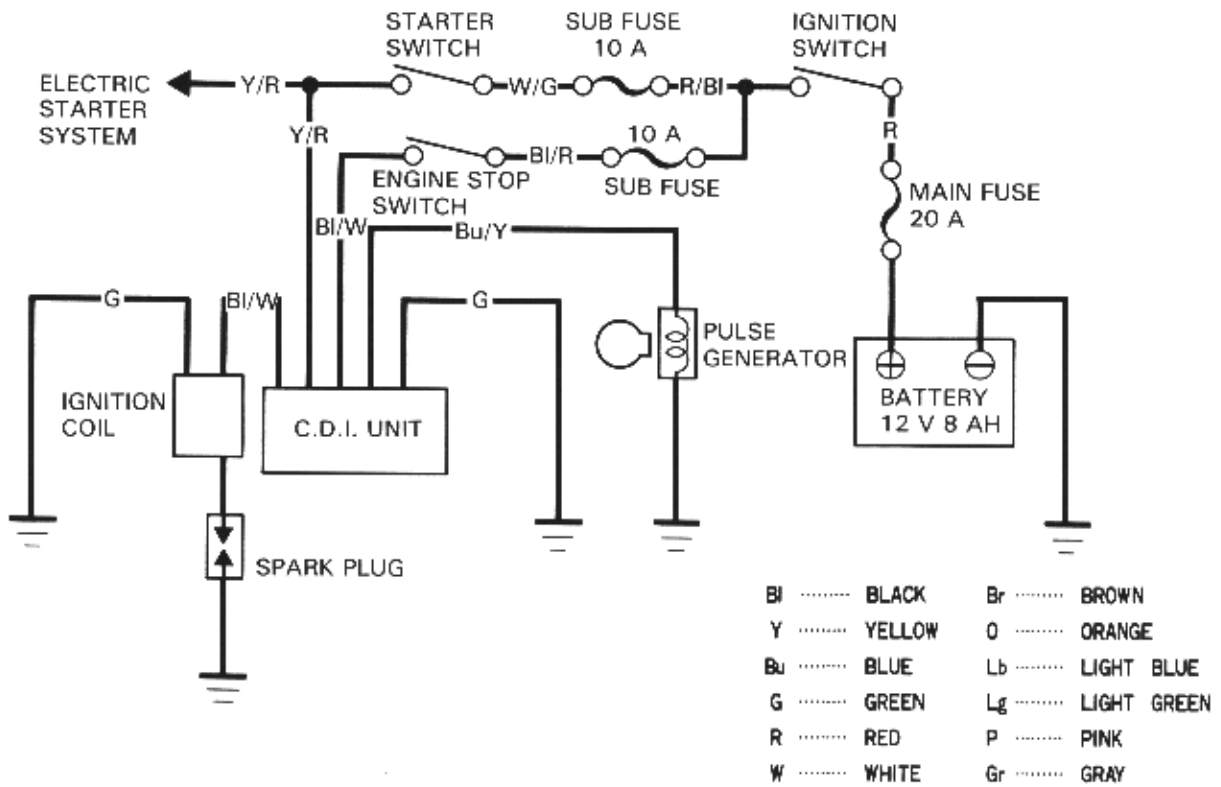
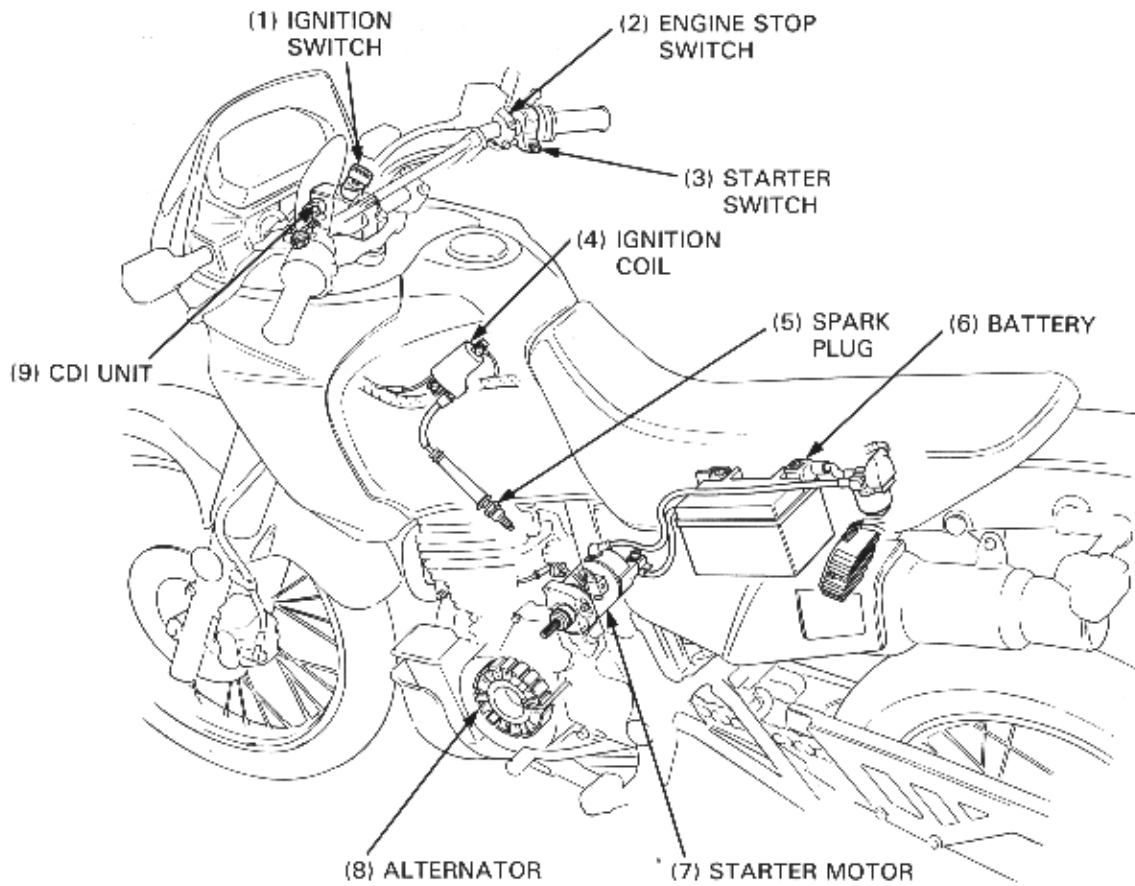

17. IGNITION SYSTEM

SYSTEM DIAGRAM	17-0	IGNITION COIL	17-5
SERVICE INFORMATION	17-1	PULSE GENERATOR	17-7
TROUBLESHOOTING	17-2	IGNITION TIMING	17-7
SYSTEM INSPECTION	17-3		

SERVICE INFORMATION

GENERAL

- When inspecting the ignition system, check the system components and lines step-by-step according to the troubleshooting sequence on the next page.
- Ignition timing cannot be adjusted since the CDI (Capacitive Discharge Ignition) unit is non-adjustable.
- For pulse generator removal and installation, see section 8.
- For alternator removal and installation, see section 9.
- For spark plug gap inspection and adjustment procedure, see page 3-6.

SPECIFICATIONS

ITEM		STANDARD
Spark plug	Standard	DPR8EA9 (NGK) X24EPR-UP (ND)
	For extended high speed riding	DPR9EA9 (NGK) X27EPR-UP (ND)
Spark plug gap		0.8–0.9 mm (0.031–0.035 in)
Ignition timing	Initial	8° BTDC at idle
	Full advance	28° BTDC at 4,000 rpm
Ignition coil resistance (20°C/68°F)	Primary coil	0.4–0.6 Ω
	Secondary coil (without spark plug cap)	10.5–16.5 kΩ
	Secondary coil (with spark plug cap)	14–23 kΩ
Pulse generator resistance (20°C/68°F)		420–520 Ω

TOOLS

Circuit tester (SANWA) or
Circuit tester (KOWA) or
Digital multimeter (KOWA)

07308–0020000
TH–5H
07411–0020000 or KS-AHM-32-003 (U.S.A. only)

1

TROUBLESHOOTING

Weak or no spark at plug

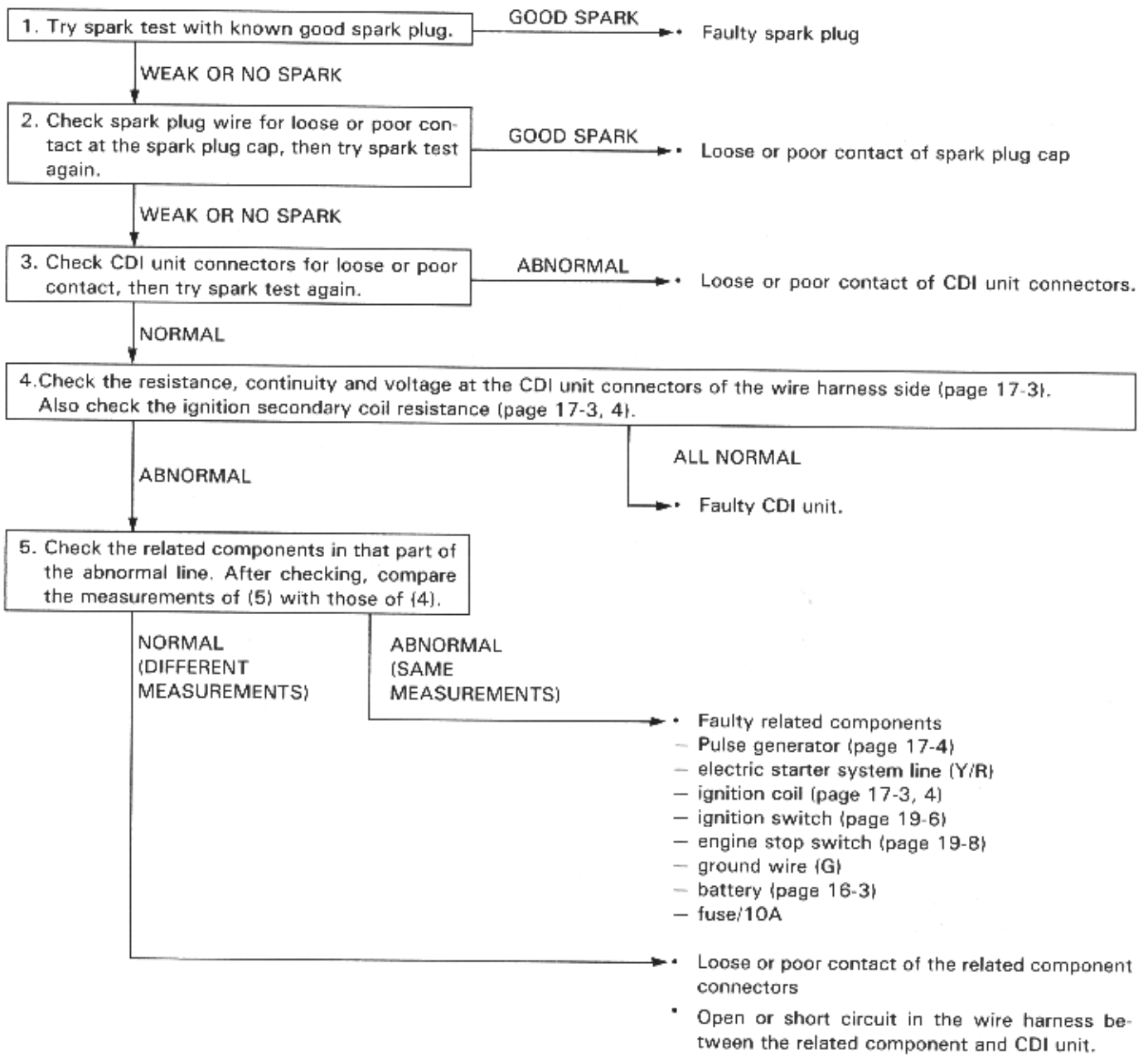

SYSTEM INSPECTION

NOTE

- Check the system components and lines step-by-step according to the troubleshooting on page 17-2.
- This method does not include an inspection of the ignition timing advance system at the CDI unit.

Remove the right fairing (page 15-2).

Disconnect the CDI unit connectors and check them for loose contact or corroded terminals.

Measure the resistance, continuity and voltage between connector terminals of the wire harness side as follows:



ITEM	TERMINAL	STANDARD
Ignition coil primary coil	Bl/Y and G	0.4—0.6 Ω (at 20°C/68°F)
Pulse generator coil	Bu/Y and G	420—520 Ω (at 20°C/68°F)
Ignition switch and engine stop switch (Turn the ignition switch ON and the engine stop switch RUN)	Bl/W (+) and G (-)	Battery voltage.
Electric starter system line (Turn the ignition switch ON and push the starter switch) NOTE: Transmission must be in neutral.	Y/R (+) and G (-)	Battery voltage.

IGNITION COIL

INSPECTION

Remove the fuel tank (page 4-3).
Measure the primary coil resistance between terminals.

STANDARD: 0.4—0.6 Ω (at 20°C/68°F)



Measure the secondary coil resistance with the spark plug cap in place by checking for continuity between the plug cap and green terminal.

STANDARD: 14—23 kΩ (at 20°C/68°F)



IGNITION SYSTEM

Remove the spark plug cap from the wires and measure the secondary coil resistance.

STANDARD: 10.5–16.5 k Ω (at 20°C, 68°F)



PULSE GENERATOR

NOTE

- It is not necessary to remove the fuel tank and fairing to make this test.

INSPECTION

Disconnect the pulse generator wire connector (2P mini).

Measure the resistance between the connector terminals.

STANDARD: 420–520 Ω (at 20°C/68°F)

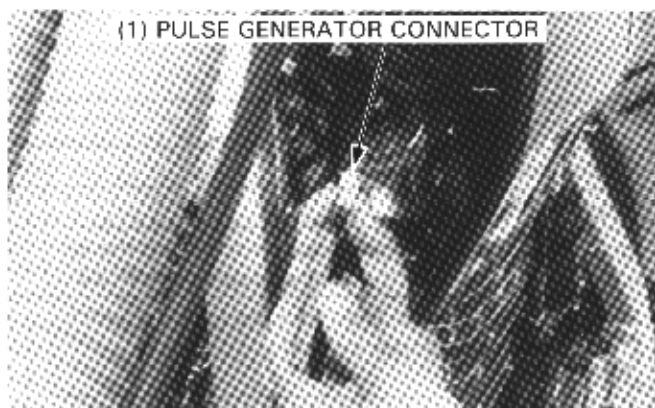

IGNITION TIMING

NOTE

- The Capacitive Discharge Ignition (CDI) system is factory pre-set and does not require adjustment. To inspect the function of the CDI components, ignition timing inspection procedures are given here.

Warm the engine up to the operating temperature.

Remove the timing hole cap.

Connect a tachometer and timing light.

Start the engine and allow it to idle.

IDLE SPEED: 1,300 \pm 100 rpm

Inspect the ignition timing.

Timing is correct if the "F" mark on the alternator rotor is aligned with the index mark on the left crankcase cover at idle.

To check the advance, raise the engine speed to 4,000 \pm 100 rpm. The index mark should be between the advance marks.

If the ignition timing is incorrect, perform the system inspection (page 17-3).

