

# HYDRAULIC BRAKE

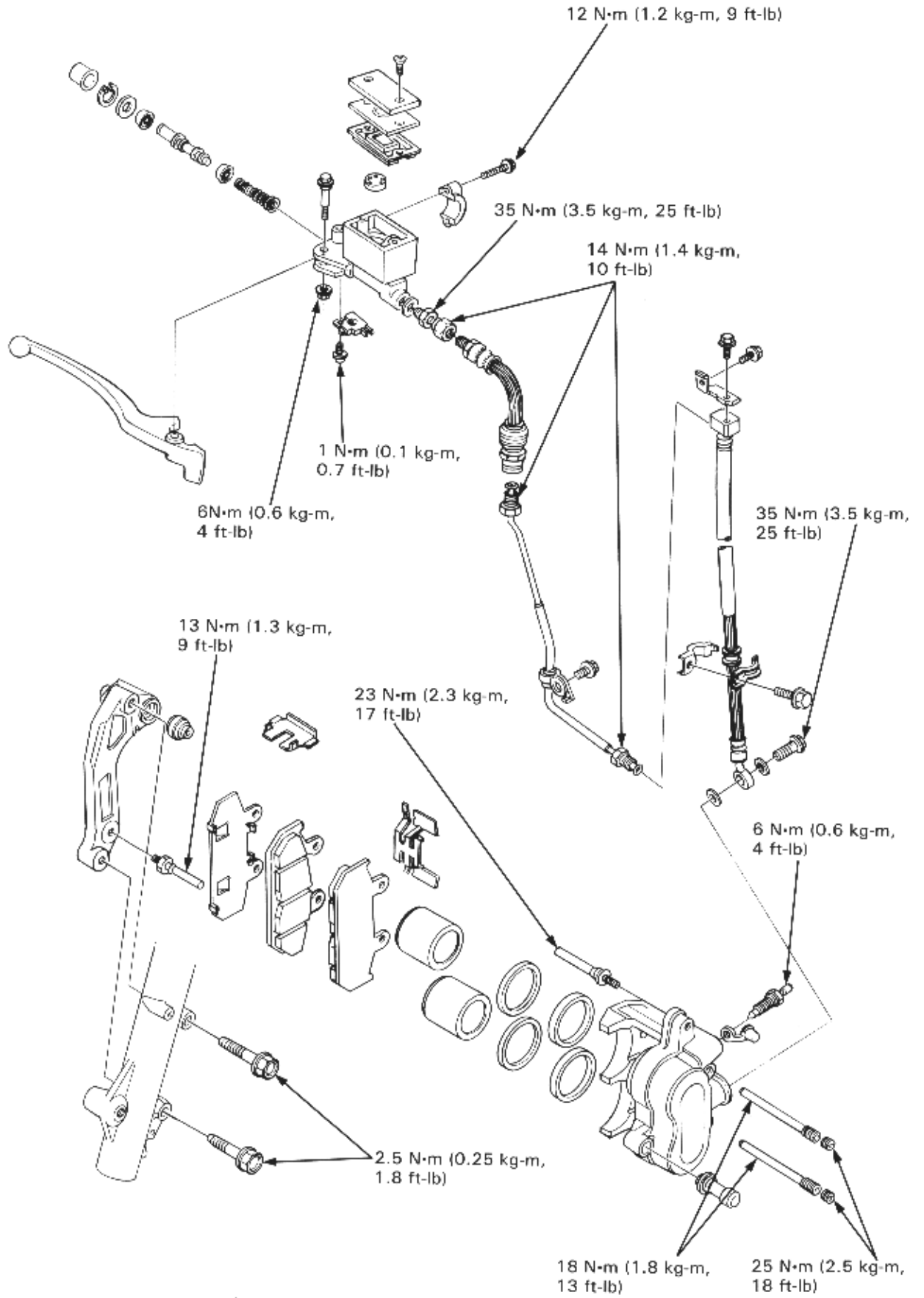

# 14. HYDRAULIC BRAKE

SERVICE INFORMATION	14-1	BRAKE PAD/DISC	14-4
TROUBLESHOOTING	14-2	MASTER CYLINDER	14-6
BRAKE FLUID REPLACEMENT/ AIR BLEEDING	14-3	BRAKE CALIPER	14-9

## SERVICE INFORMATION

### GENERAL

#### ▲ WARNING

- *A contaminated brake disc or pad reduces stopping power. Discard contaminated pads and clean a contaminated disc with a high quality brake degreasing agent.*
- The brake calipers can be removed without disconnecting the hydraulic system.
- Bleed the hydraulic system if it has been disassembled or if the brake feels spongy.
- Do not allow foreign material to enter the system when filling the reservoir.
- Avoid spilling brake fluid on painted, plastic or rubber parts. Place a rag over these parts whenever the system is serviced.
- Always check brake operation before riding the motorcycle.

### SPECIFICATIONS

ITEM	STANDARD	SERVICE LIMIT
Disc thickness	3.5 mm (0.14 in)	3.0 mm (0.12 in)
Disc runout	—	0.30 mm (0.012 in)
Master cylinder I.D.	12.700–12.743 mm (0.5000–0.5017 in)	12.75 mm (0.502 in)
Master piston O.D.	12.65–12.684 mm (0.4983–0.4994 in)	12.64 mm (0.498 in)
Caliper cylinder I.D.	32.030–32.080 mm (1.2610–1.2630 in)	32.11 mm (1.264 in)
Caliper piston O.D.	31.948–31.998 mm (1.2578–1.2598 in)	31.90 mm (1.256 in)

### TORQUE VALUES

Bleed valve	6 N·m (0.6 kg-m, 4 ft-lb)
Front brake caliper bracket bolt	28 N·m (2.8 kg-m, 20 ft-lb)
Hanger pin	18 N·m (1.8 kg-m, 13 ft-lb)
Hanger pin plug	25 N·m (0.25 kg-m, 1.8 ft-lb)
Brake lever pivot nut	6 N·m (0.6 kg-m, 4 ft-lb) Apply oil to the threads
Brake light switch screw	12 N·m (1.2 kg-m, 9 ft-lb)
Master cylinder holder bolt	12 N·m (1.2 kg-m, 9 ft-lb)
Brake hose nut (master cylinder side)	35 N·m (3.5 kg-m, 25 ft-lb)
Brake hose joint nut	14 N·m (1.4 kg-m, 10 ft-lb)
Brake hose bolt	35 N·m (3.5 kg-m, 25 ft-lb)
Caliper pin bolt	23 N·m (2.3 kg-m, 17 ft-lb) Apply a locking agent to the threads
Caliper bracket pin bolt	13 N·m (1.3 kg-m, 9 ft-lb) Apply a locking agent to the threads

### TOOL

<b>Special</b>	
Snap ring pliers	07914–3230001

### TROUBLESHOOTING

#### **Brake lever soft or spongy**

- Air in hydraulic system
- Low fluid level
- Hydraulic system leaking

#### **Brake lever too hard**

- Sticking piston(s)
- Clogged hydraulic system
- Pads grazed or worn excessively

#### **Brakes drag**

- Hydraulic system leaking
- Sticking piston(s)

#### **Brakes grab or pull to one side**

- Pads contaminated
- Disc or wheel misaligned

#### **Brake chatter or squeal**

- Pads contaminated
- Pads worn
- Excessive disc run out
- Caliper installed incorrectly
- Disc or wheel misaligned

## BRAKE FLUID REPLACEMENT/ AIR BLEEDING

### ⚠ WARNING

- *A contaminated brake disc or pad reduces stopping power. Discard contaminated pads and clean a contaminated disc with a high quality brake degreasing agent.*

### CAUTION

- *Do not allow foreign material to enter the system when filling the reservoir.*
- *Avoid spilling fluid on painted, plastic or rubber parts. Place a rag over these parts whenever the system is serviced.*
- *Use DOT 3 or DOT 4 brake fluid from a sealed container.*
- *Do not mix brake fluid types and never reuse drained fluid.*

### BRAKE FLUID DRAINING

Connect a bleed hose to the bleed valve.  
Remove the reservoir cover.

### NOTE

- **Be sure the fluid reservoir is parallel to the ground before removing the cover and diaphragm.**

Loosen the caliper bleed valve and slowly pump the brake lever.

Stop moving the lever when fluid stops flowing out of the bleed valve.

### BRAKE FLUID FILLING

### NOTE

- **Check the fluid level often while bleeding the brakes to prevent air from being pumped into the system.**
- **When using the Brake Bleeder, follow the manufacturer's instructions.**
- **Do not mix brake fluid types and never reuse the fluid which has been pumped out during brake bleeding, because it may impair the efficiency of the brake system.**

Close the bleeder valve, fill the reservoir with DOT 3 or DOT 4 brake fluid to the upper level.

Install the diaphragm and reservoir cover.

Connect a Brake Bleeder or equivalent to the bleed valve.

Pump the brake bleeder and loosen the bleed valve. Add fluid when the fluid level in the master cylinder reservoir is low. Repeat above procedures until no air bubbles appear in the plastic hose.

### NOTE

- **If air entering the bleed from around the bleed valve threads, seal the threads with teflon tape.**

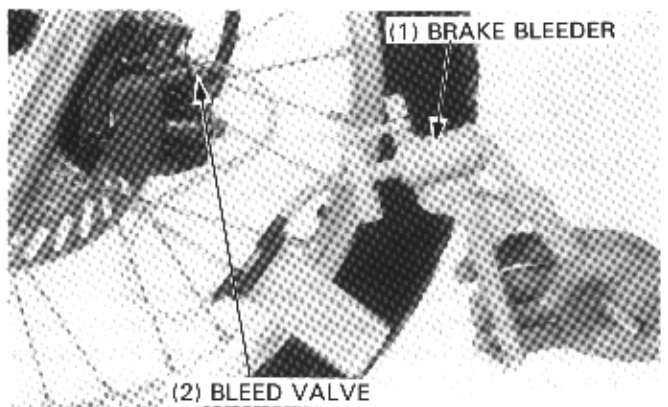
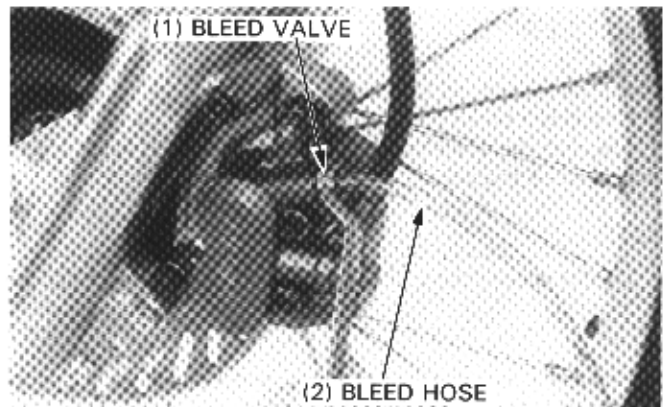
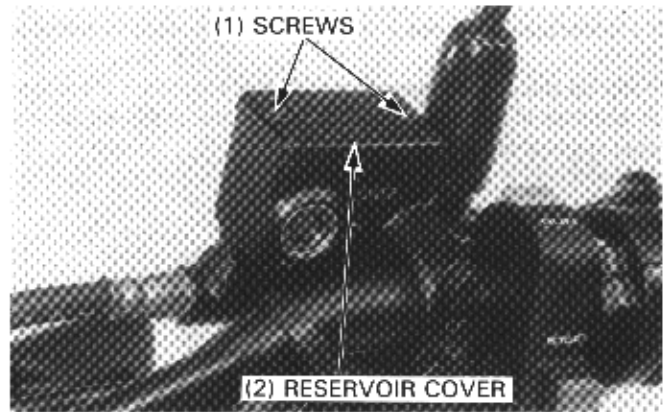

## HYDRAULIC BRAKE

If a brake bleeder is not available, fill the system as follows:

Pump up the system pressure with the lever until there are no air bubbles in the fluid flowing out of the reservoir hole and lever resistance is felt.

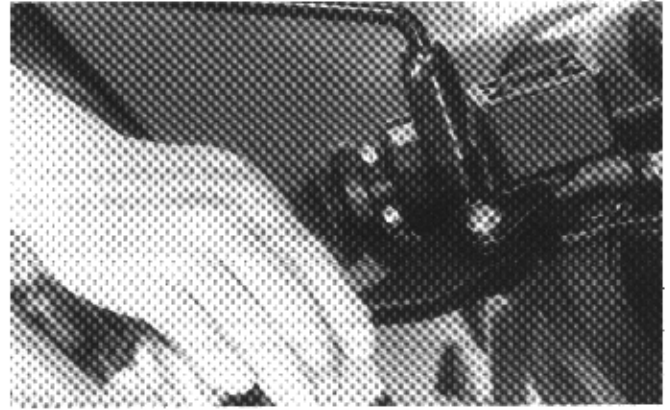

### AIR BLEEDING

Bleed the system as follows:

- 1) Connect a bleed hose to the bleed valve.
- 2) Squeeze the brake lever, then open the bleed valve 1/2 turn and close the valve.

#### NOTE

- Do not release the brake lever until the bleed valve has been closed.

- 3) Release the brake lever slowly and wait several seconds after it reaches the end of its travel.

Repeat steps 2 and 3 until bubbles cease to appear in the fluid at the end of the hose.

Tighten the bleed valve.

**TORQUE: 6 N·m (0.6 kg-m, 4 ft-lb)**

Close the bleed valve, fill the reservoir with DOT 3 or DOT 4 brake fluid to the upper level.

Reinstall the diaphragm and reservoir cover.

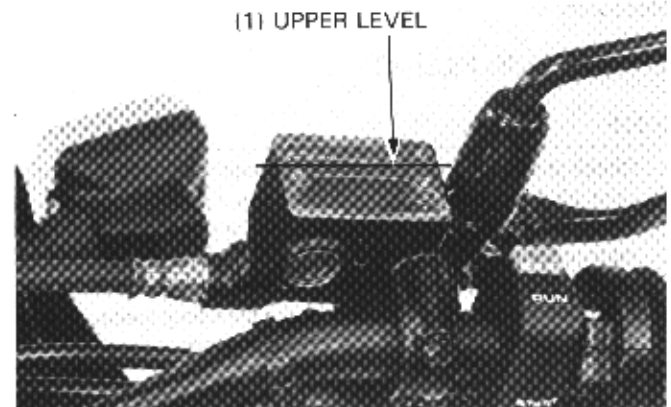
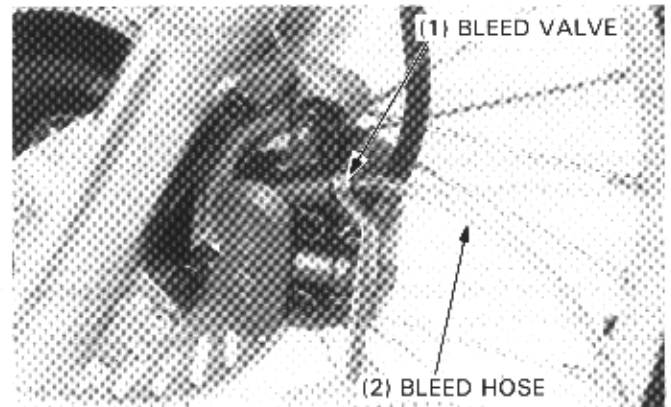

## BRAKE PAD/DISC

### PAD REPLACEMENT

#### NOTE

- Always replace the brake pads in pairs to assure even disc pressure.
- It is unnecessary to disconnect the brake hose to replace the brake pads.

Remove the brake hose clamp from the fork slider.  
Remove the hanger pin plugs and loosen the hanger pins.  
Remove the caliper bracket bolts and separate the brake caliper and caliper bracket assembly from the brake disc.  
Separate the bracket from the caliper.

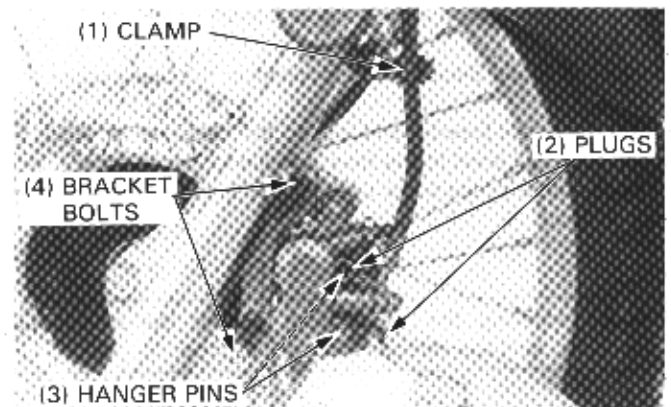

Pry one old pad against the caliper with a screwdriver to push the pistons into the caliper.

Remove the hanger pins and brake pads from the brake caliper.

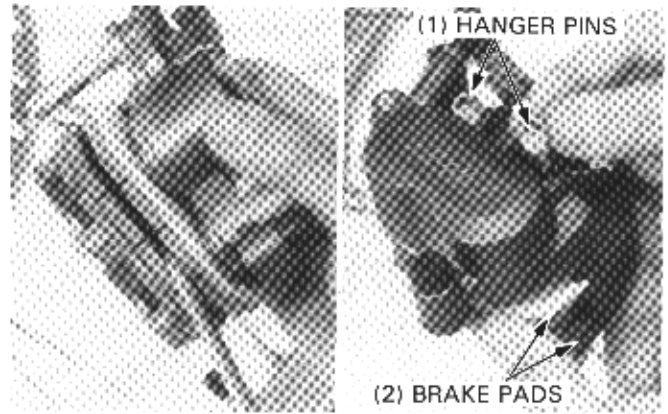

Position the pad spring in the caliper as shown.

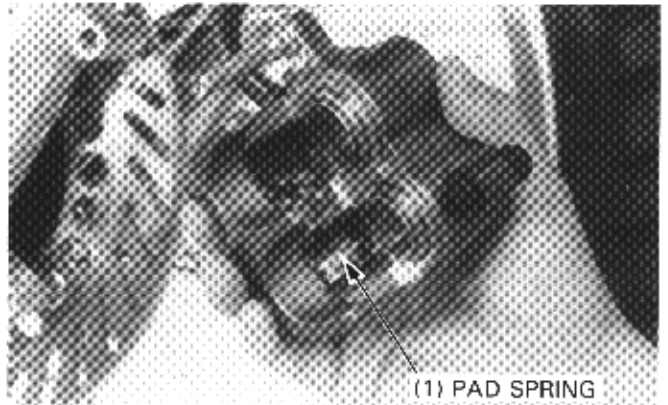

Install new pads in the caliper.

Install the pad pins; one pad pin first, then install the other pin by pushing the pads against the caliper to depress the pad spring.

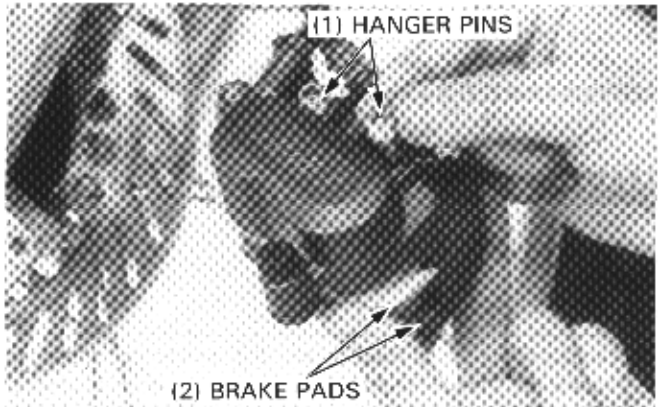

Make sure that the brake pad retainer is installed securely. Apply silicone grease to the caliper pin bolt and caliper bracket pin bolt.

Install the bracket to the caliper, aligning the pad end with the pad retainer.

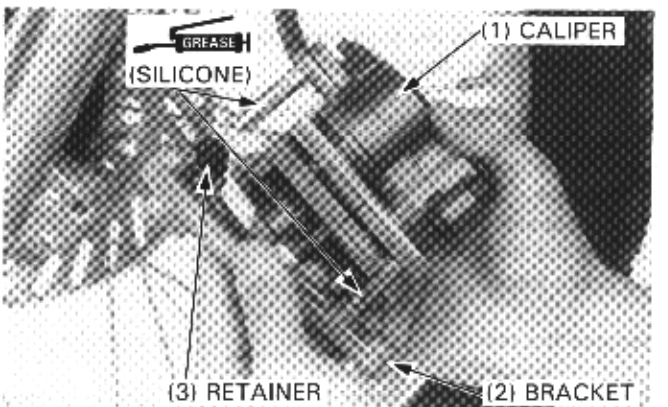

## HYDRAULIC BRAKE

With the caliper bracket, set the caliper onto the brake disc with the disc between the pads.

### NOTE

- When installing the caliper, be careful not to damage the brake pads with the disc.

Tighten the caliper bracket bolts.

**TORQUE: 27 N-m (2.7 kg-m, 20 ft-lb)**

Tighten the hanger pin.

**TORQUE: 18 N-m (1.8 kg-m, 13 ft-lb)**

Install and tighten the hanger pin plugs.

**TORQUE: 2.5 N-m (0.25 kg-m, 1.8 ft-lb)**

Secure the brake hose with the brake hose clamp.

### DISC THICKNESS

Measure the thickness of disc.

**SERVICE LIMIT: 3.0 mm (0.12 in)**

### BRAKE DISC WARPAGE

Measure brake disc for warpage on a surface plate.

**SERVICE LIMIT: 0.30 mm (0.012 in)**

## MASTER CYLINDER

### REMOVAL

#### CAUTION

- Avoid spilling brake fluid on painted, plastic or rubber parts. Place a rag over these parts whenever the system is serviced.

### NOTE

- When removing the fluid hose, cover the end of the brake pipe to prevent contamination.

Drain the brake fluid from the brake system (page 14-3). Loosen the brake hose joint while holding the brake hose nut (brake pipe side) with a wrench. Free the brake hose from the clamp. Loosen the brake hose nut (master cylinder side) and remove the brake hose.

Remove the rear view mirror from the master cylinder.

Remove the master cylinder holder bolts, holder and master cylinder.

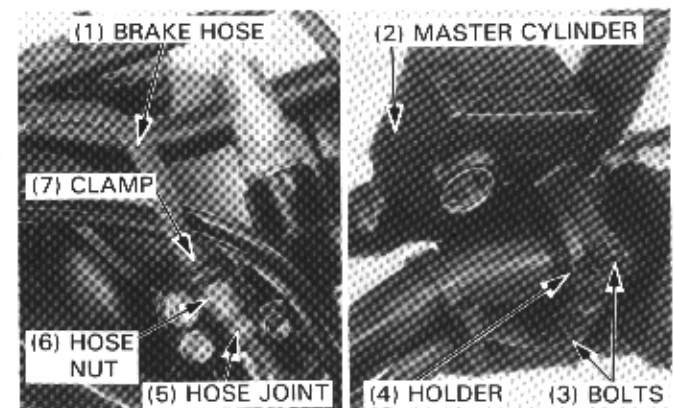
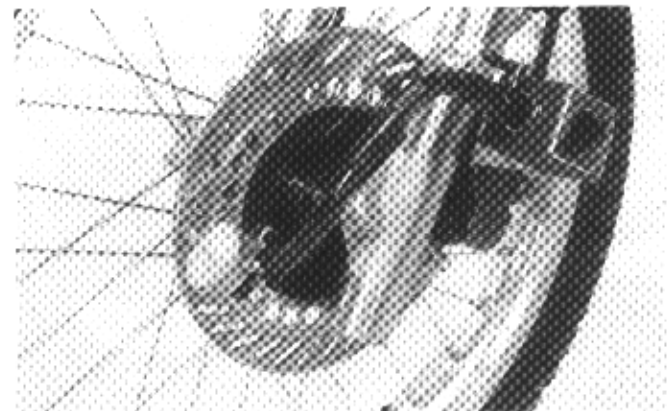
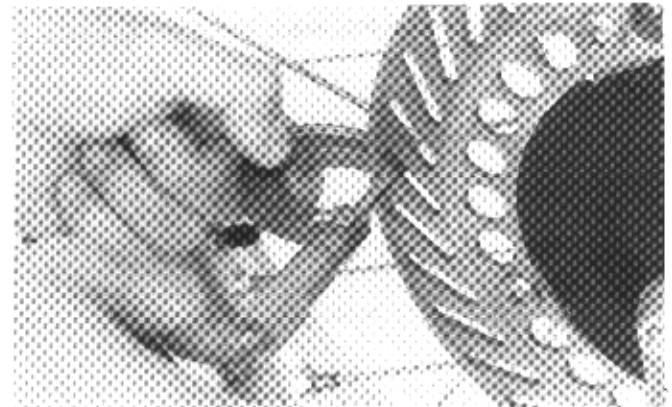
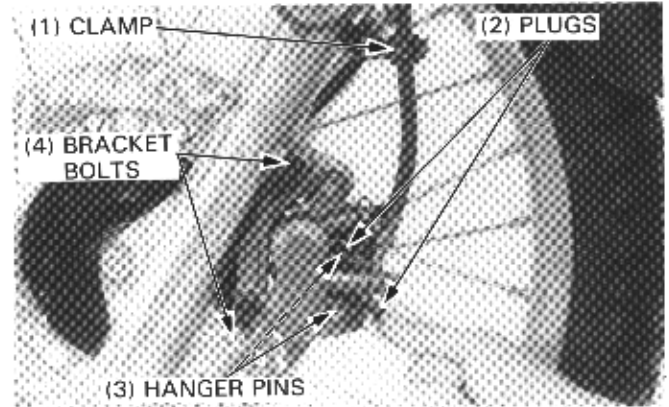

Remove the front brake light switch.  
Remove the pivot nut, bolt and brake lever.

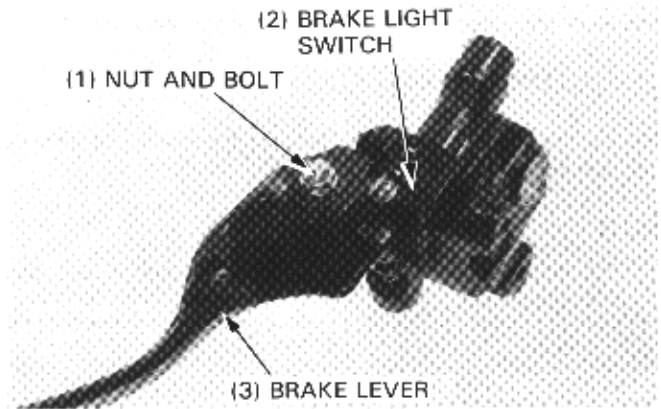

**DISASSEMBLY**

Remove the piston boot.

**NOTE**

- Be careful not to damage the piston boot when removing it.

Remove the snap ring from the master cylinder body.

**TOOL:**

Snap ring pliers 07914-3230001

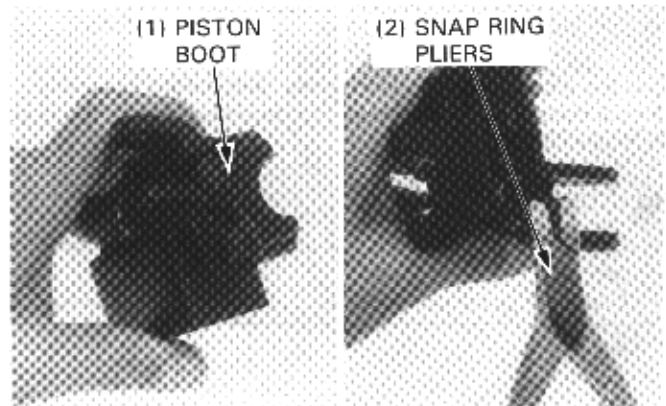

Remove the washer, master piston with the piston cups and spring from the master cylinder.

Clean the inside of the master cylinder and reservoir with clean brake fluid.

**NOTE**

- Clean the disassembled parts with brake fluid and make sure air can flow through the master cylinder port by applying compressed air.

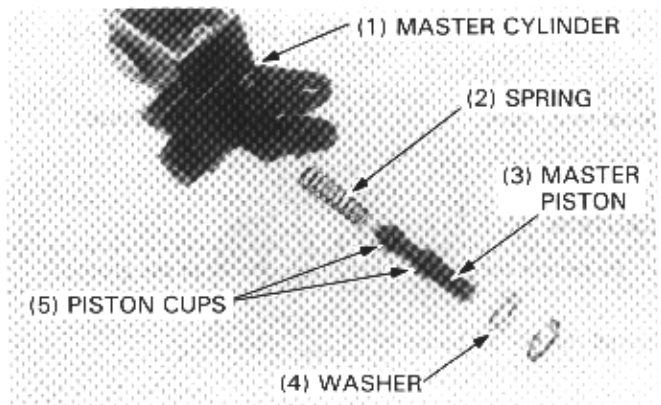

**INSPECTION**

Check the master cylinder for scores, scratches or nicks.  
Measure the master cylinder I.D.

**SERVICE LIMIT: 12.75 mm (0.502 in)**

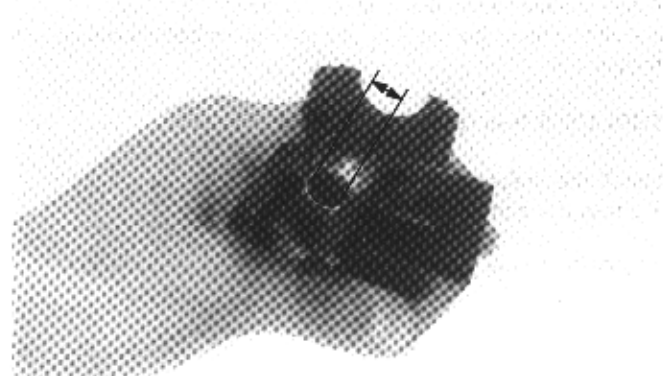



## HYDRAULIC BRAKE

Measure the master piston O.D. at the primary cap.

**SERVICE LIMIT: 12.64 mm (0.498 in)**

Before the assembly, check the primary and secondary caps for damage or fatigue.

### NOTE

- The master cylinder piston, cups and spring must be replaced as a set.

### ASSEMBLY

Dip the piston cups in clean brake fluid before assembly. Install the spring and primary cup together. Install the master cylinder piston.

### CAUTION

- When installing the cups, do not allow the lips to turn inside out.
- Install the spring with its tapered end toward the master piston.

Install the snap ring to the master cylinder body.

### TOOL:

Snap ring pliers **07914-3230001**

### CAUTION

- Be certain the snap ring is firmly seated in the groove.

Install the piston boot.

Apply grease to the brake lever pivots.

Install the pivot bolt and tighten the pivot bolt to the specified torque.

**TORQUE: 6 N·m (0.6 kg-m, 4 ft-lb)**

Install the brake light switch.

Tighten the screw to the specified torque.

**TORQUE: 1 N·m (0.1 kg-m, 0.7 ft-lb)**

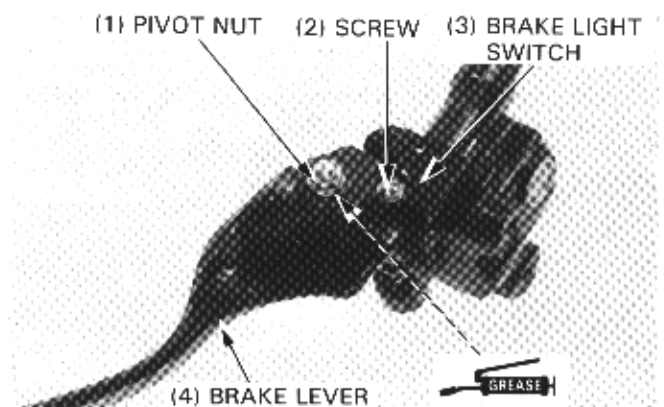
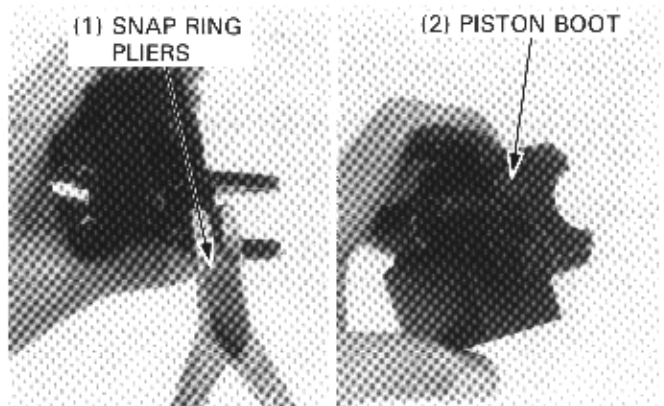
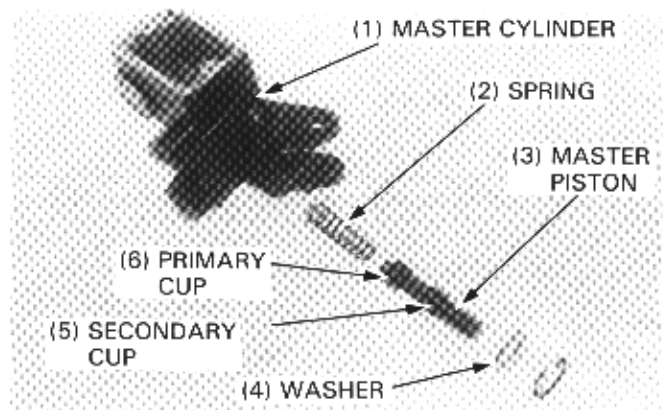

Install the master cylinder and master cylinder holder and secure them with two bolts.

**TORQUE: 12 N·m (1.2 kg-m, 9 ft-lb)**

**NOTE**

- Install the master cylinder holder with its "UP" mark facing up.
- Align the master cylinder mating surface with the punch mark on the handlebar.
- Tighten the upper bolt first then the lower one.

Connect the brake hose to the master cylinder and tighten the brake hose bolt with a new sealing washer.

**TORQUE: 35 N·m (3.5 kg-m, 25 ft-lb)**

Secure the brake hose with the clamp. Tighten the brake hose joint nut while holding the brake hose nut (brake pipe side) with a wrench.

**TORQUE: 14 N·m (1.4 kg-m, 10 ft-lb)**

Connect the front brake switch wires. Fill and bleed the front brake system (page 14-3). Check the front brake system for leaking.

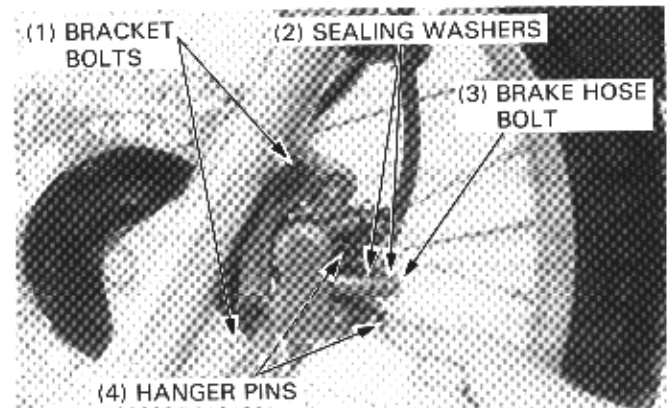
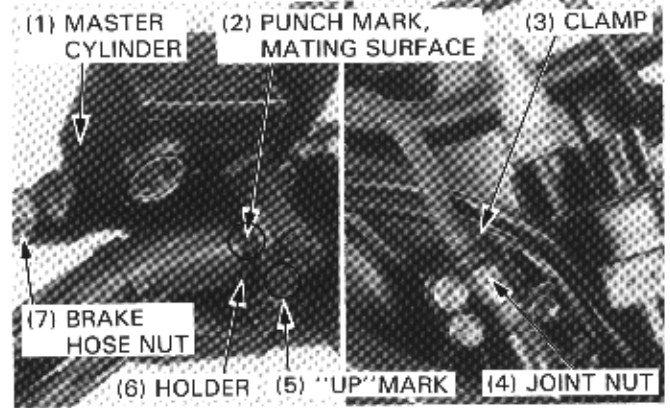

**BRAKE CALIPER**

**REMOVAL**

Place a clean container under the caliper and disconnect the brake hose from brake caliper.

**CAUTION**

- *Avoid spilling brake fluid on painted surfaces.*

Loosen the hanger pins (page 14-4). Remove the caliper bracket bolts and remove the caliper and caliper bracket as an assembly.

Remove the hanger pins and pads (page 14-5).

Remove the followings from the brake caliper.

- Caliper bracket
- Pad spring
- Pivot boots

**DISASSEMBLY**

Position the caliper with the pistons down and apply short bursts of air pressure to the fluid inlet.

**▲ WARNING**

- *Do not use high pressure air or bring the nozzle too close to the inlet.*
- *Place a shop towel over the pistons to prevent them from flying out.*

Check the pistons and cylinders for scoring, scratches or other damage and replace if necessary.

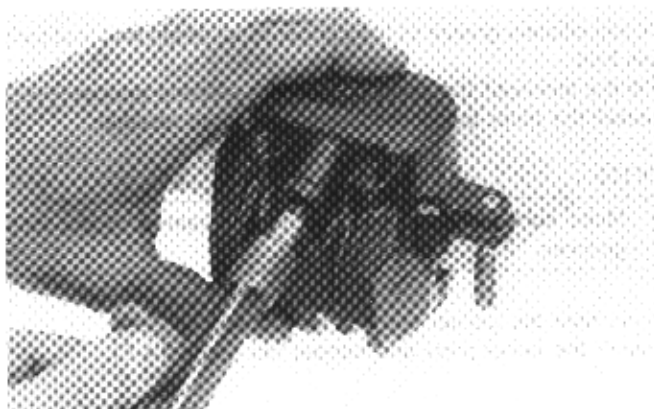
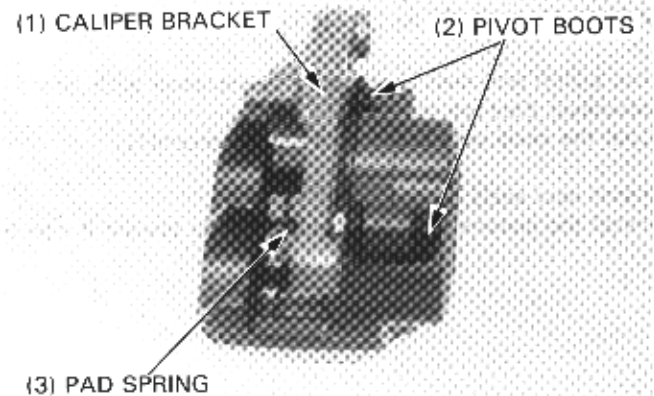

## HYDRAULIC BRAKE

Push the piston and dust seals in, lift them out and discard them.

### CAUTION

- *Be careful not to damage the piston sliding surfaces when removing the seals.*

Clean the caliper cylinders, seal grooves and caliper pistons with clean brake fluid.

### INSPECTION

Check the pistons for scoring, scratches or other damage. Measure the piston O.D.

**SERVICE LIMIT: 31.90 mm (1.256 in)**

Check the caliper cylinder for scoring, scratches or other damage. Measure the caliper cylinder bore.

**SERVICE LIMIT: 32.11 mm (1.264 in)**

### ASSEMBLY/INSTALLATION

The piston and dust seals must be replaced with new ones whenever they are removed. Coat the seals with brake fluid before assembly.

Install new seals.

Install the pistons with the insulated ends toward the pads.

Apply silicone grease to the caliper bracket pin bolt and caliper pin bolt.

Fill the inside of the pivot boots with silicone grease. Install the pivot boots, pad spring and pad retainer.

### NOTE

- Make sure that the pivot boots are seated in the caliper grooves.

Assemble the caliper and caliper bracket. Install the brake pads and hanger pin (page 14-5).

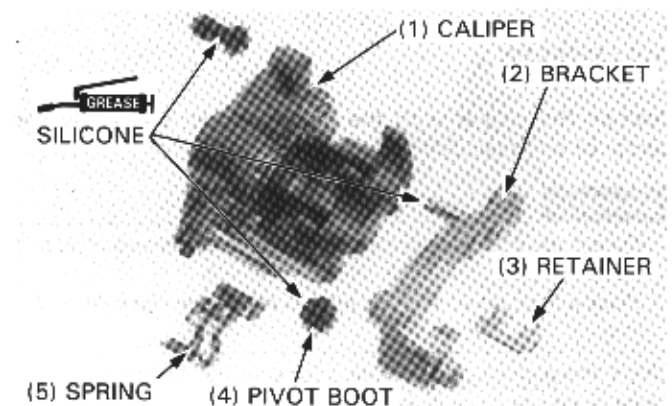
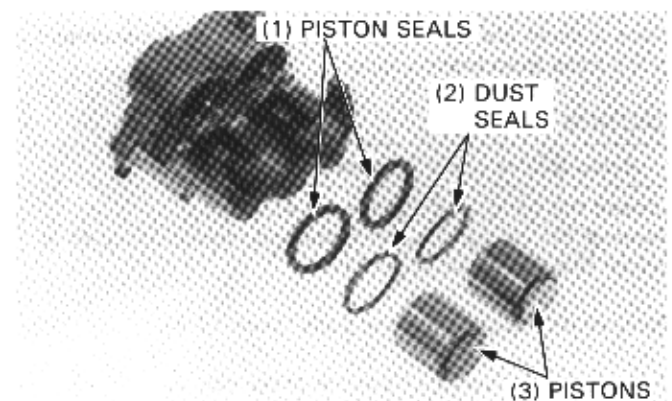
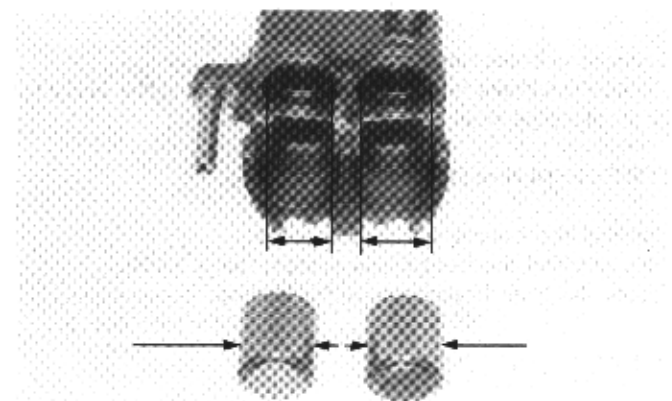
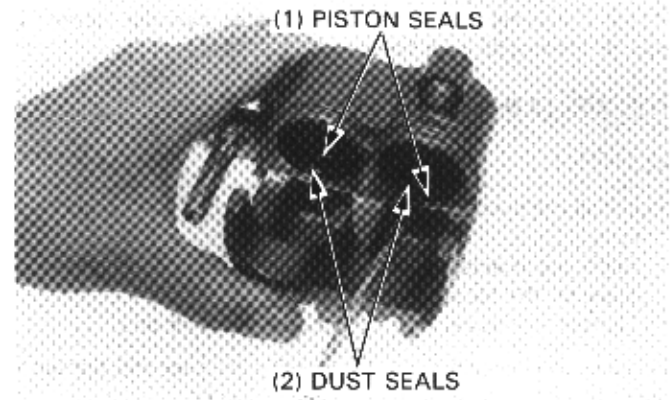

**INSTALLATION**

Install the caliper assembly over the brake disc so that the disc is positioned between the pads.

**CAUTION**

- *Be careful not to damage the brake pads with the brake disc.*

Tighten the caliper bracket bolts.

**TORQUE: 27 N·m (2.7 kg-m, 20 ft-lb)**

Connect the brake hose to the caliper with the new sealing washers and hose bolt.

Tighten the brake hose bolt.

**TORQUE: 35 N·m (3.5 kg-m, 25 ft-lb)**

Tighten the hanger pins.

**TORQUE: 18 N·m (1.8 kg-m, 13 ft-lb)**

Install the and tighten the hanger pin plugs.

**TORQUE: 2.5 N·m (0.25 kg-m, 1.8 ft-lb)**

Secure the brake hose with the clamp.

Fill and bleed front brake system (page 14-3).

