

# 15. FAIRING/EXHAUST SYSTEM

SERVICE INFORMATION	15-1	REAR FENDER	15-5
SIDE COVER/SEAT	15-2	EXHAUST PIPE/MUFFLER	15-7
FAIRING	15-2		

## SERVICE INFORMATION

### GENERAL

#### **▲** WARNING

- *Do not service the exhaust system while it is hot.*

### TORQUE VALUES

Exhaust pipe joint nut	22 N•m (2.2 kg-m, 16 ft-lb)
Muffler band bolt	20 N•m (2.0 kg-m, 14 ft-lb)
Muffler bolt	25 N•m (2.5 kg-m, 18 ft-lb)
Exhaust pipe heat protector bolt	10 N•m (1.0 kg-m, 7 ft-lb) Apply locking agent to the threads
Rear carrier mounting bolt (AFTER '88)	35 N•m (3.5 kg-m, 25 ft-lb)

## FAIRING/EXHAUST SYSTEM

### SIDE COVER/SEAT

#### REMOVAL/INSTALLATION

Remove the side cover bolts, and remove the side covers by pulling the cover studs out of the gromets.

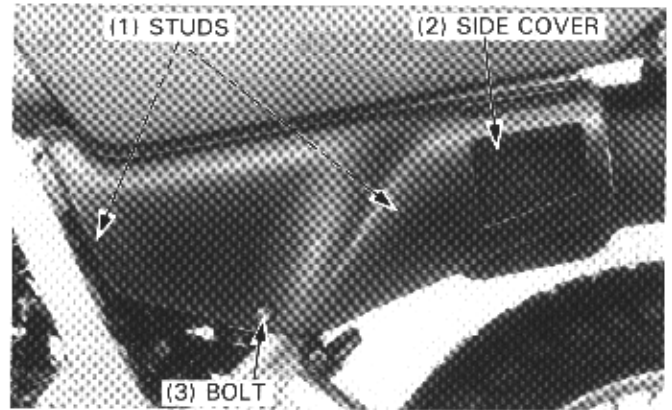

Remove the seat bolts and remove the seat, sliding it back.

Install the seat and side covers in the reverse order of the removal.

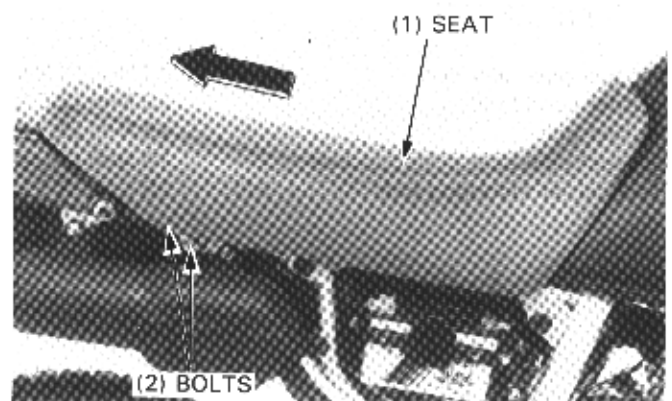

### FAIRING

#### REMOVAL/INSTALLATION

Remove the two screws and right and left fairing cover. Remove the two screws and inner cover.

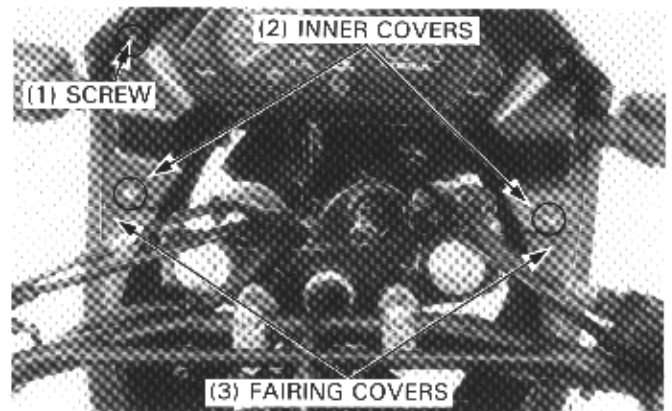

Remove the center fairing and windshield by removing four screws.

Remove the front grille by removing the four screws.

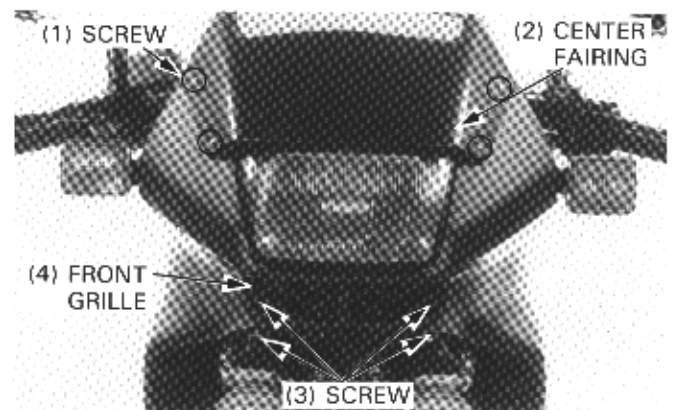

Remove the screws and right and left air guides.

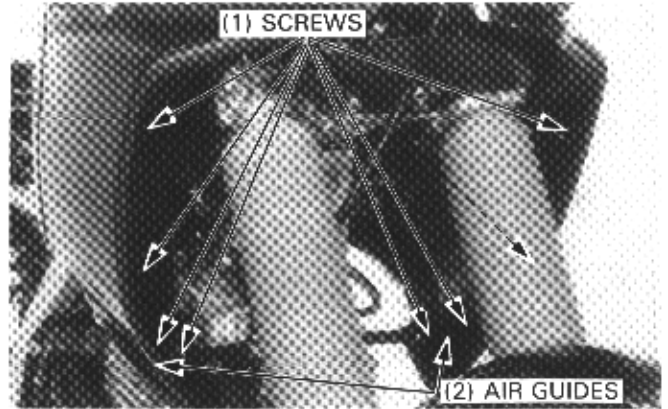

Remove the two screws and headlight plate.

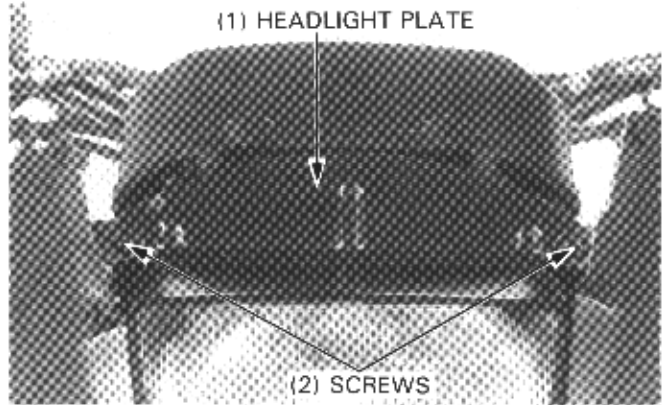

Remove the right and left fairings by removing the screws and pulling the stud out of the fuel tank gromet.

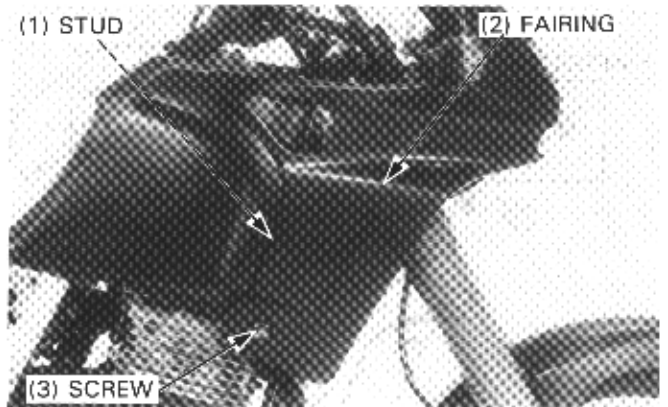

# FAIRING/EXHAUST SYSTEM

Install the removed parts in the reverse order of the removal.

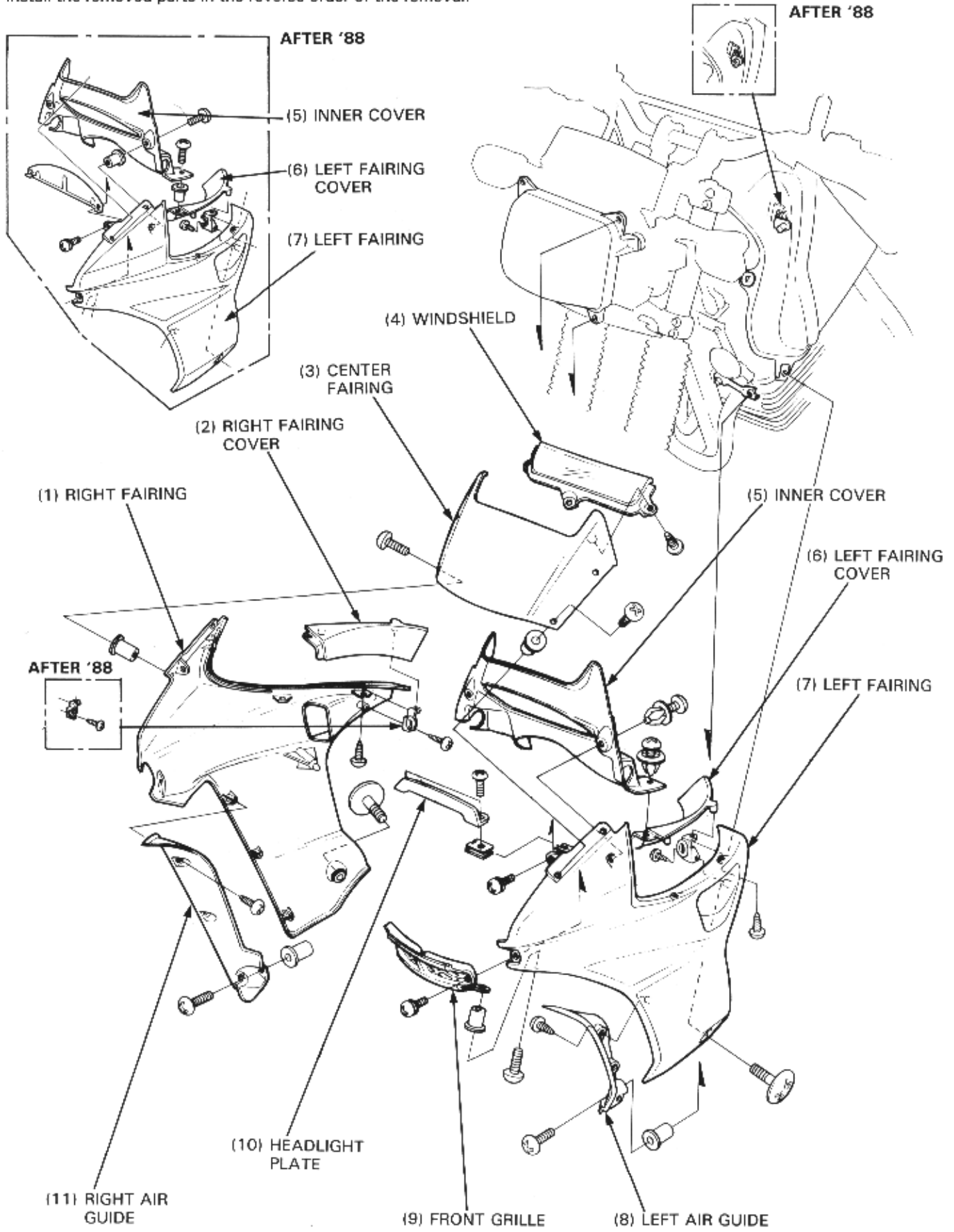

**REAR FENDER****REMOVAL/INSTALLATION****'88:**

Remove the seat (page 15-2), and disconnect the rear turn signal and tail/brakelight connectors.

Remove the rear turn signal light bolts, fender mounting bolts and rear fender assembly.

If necessary, separate the rear fender B from the rear fender A by removing three nuts.

Install the rear fender assembly in the reverse order of the removal.

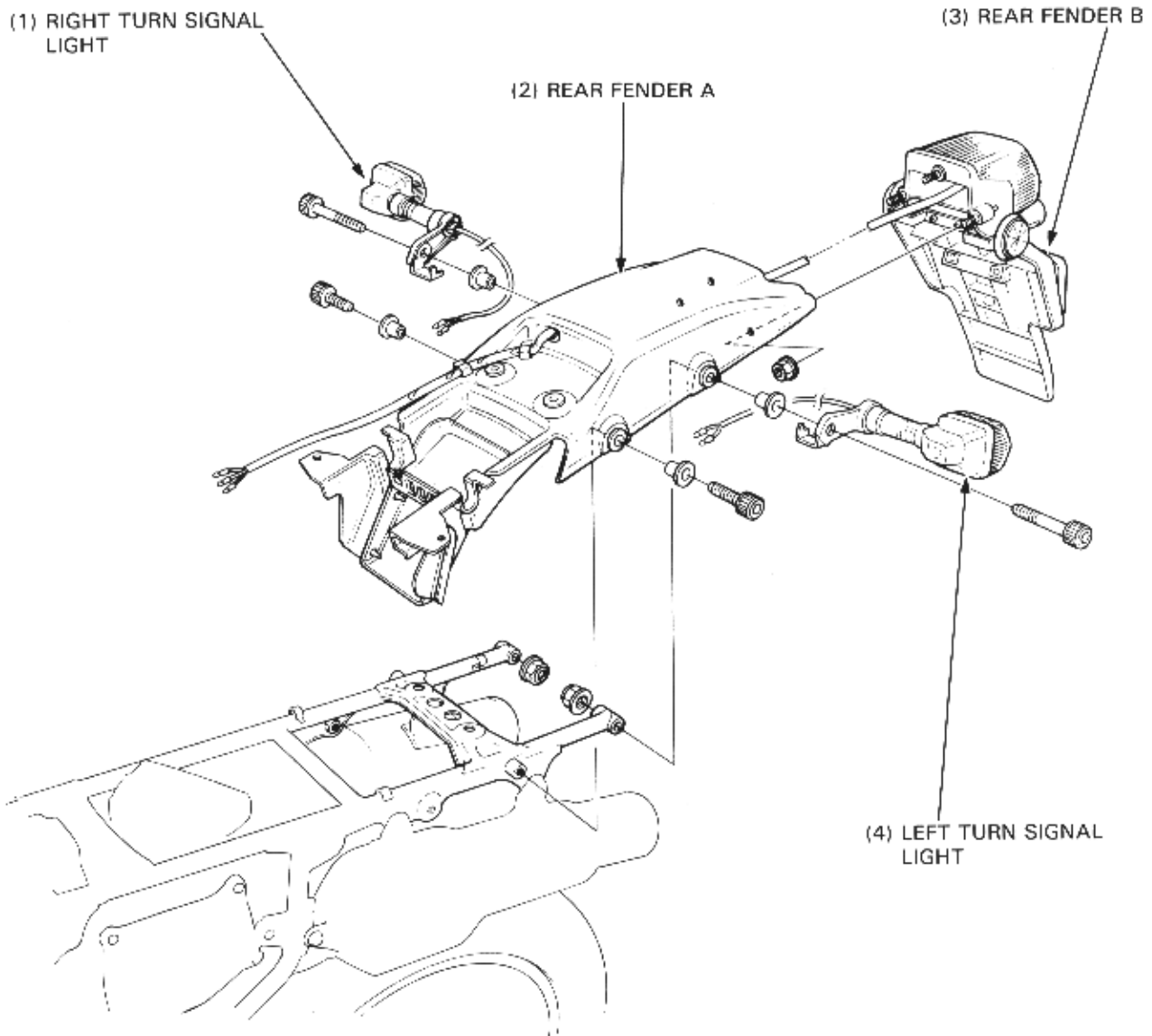
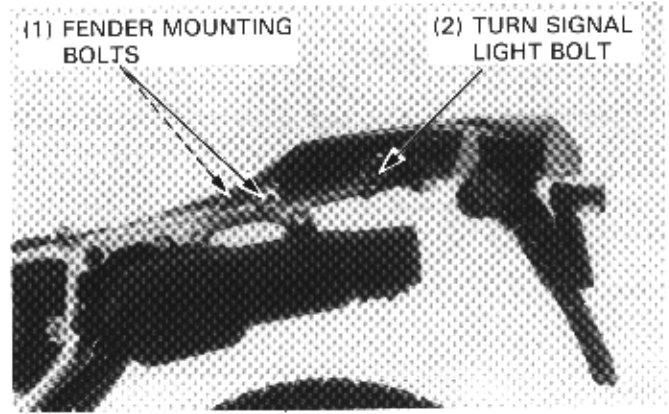

## FAIRING/EXHAUST SYSTEM

### AFTER 88:

Remove the seat (page 15-2).

Disconnect the rear turn signal and tail/brakelight connectors. Remove the four rear carrier mounting bolts, rear carrier and rear turn signals.

Remove the rear fender A, rear fender B, and rear fender mount by removing the two bolts.

Install the removed parts in the reverse order of the removal.

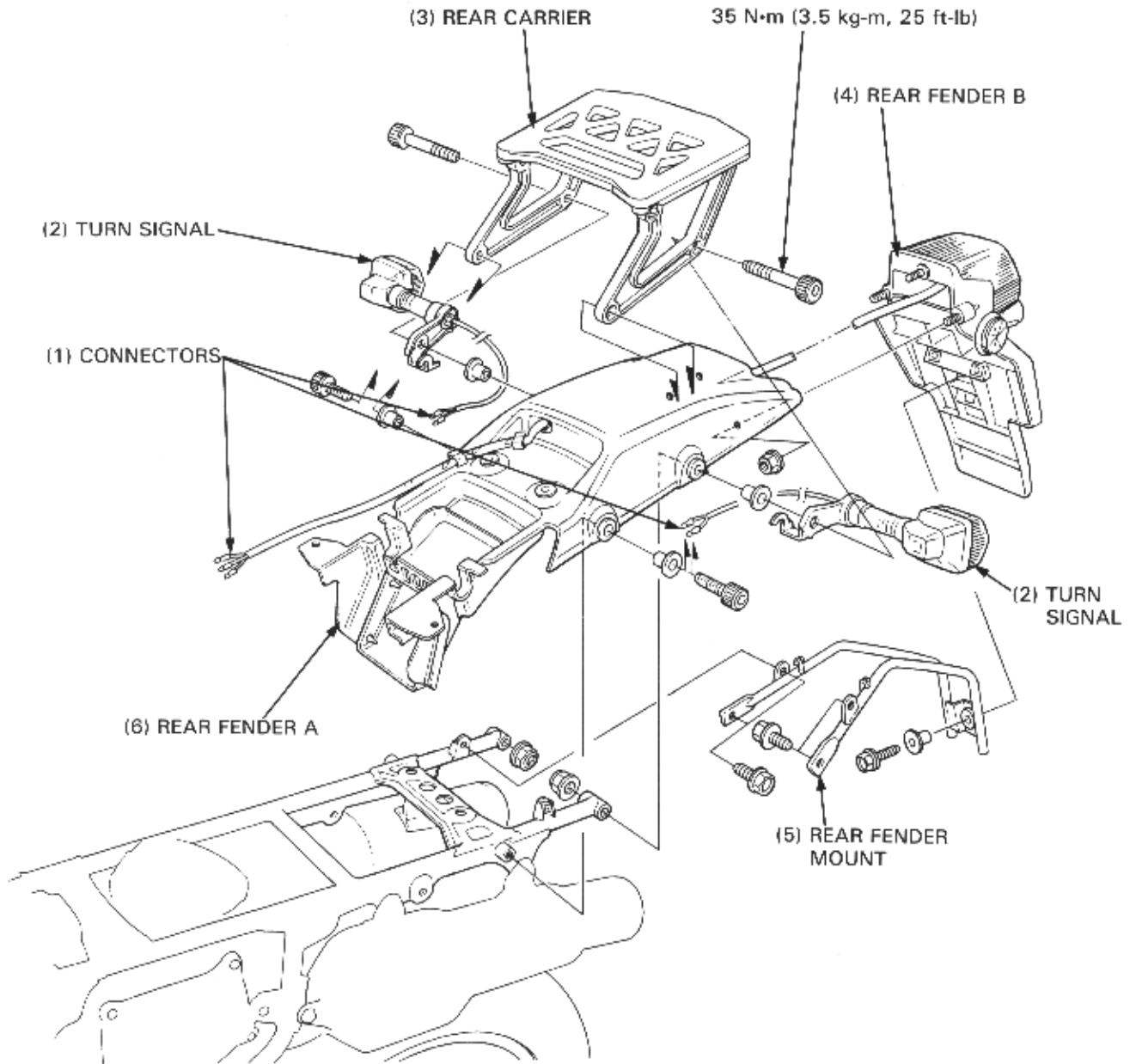

## EXHAUST PIPE/MUFFLER

### EXHAUST PIPE REMOVAL

Remove the right side cover (page 15-2).

Loosen the muffler band bolts, and remove the exhaust pipe joint nuts, exhaust pipes joint collars and exhaust pipe gaskets.

#### NOTE

- Whenever the exhaust pipe gaskets are removed, replace with new ones.

Remove the exhaust pipe heat protector, if necessary.

### EXHAUST MUFFLER REMOVAL

Remove the side covers (page 15-2).

Loosen the muffler band bolts, and remove the muffler bolts and mufflers.

Install the removed parts in the reverse order of the removal, and tighten the bolts and nuts to the specified torque.

#### TORQUE:

Exhaust pipe joint nut: 22 N·m (2.2 kg-m, 16 ft-lb)

Muffler band bolt: 20 N·m (2.0 kg-m, 14 ft-lb)

Muffler bolt: 25 N·m (2.5 kg-m, 18 ft-lb)

Exhaust pipe heat protector bolt:

10 N·m (1.0 kg-m, 7 ft-lb) Apply a locking agent to the threads.

