

**ELECTRIC STARTER SYSTEM**

**SYSTEM DIAGRAM**

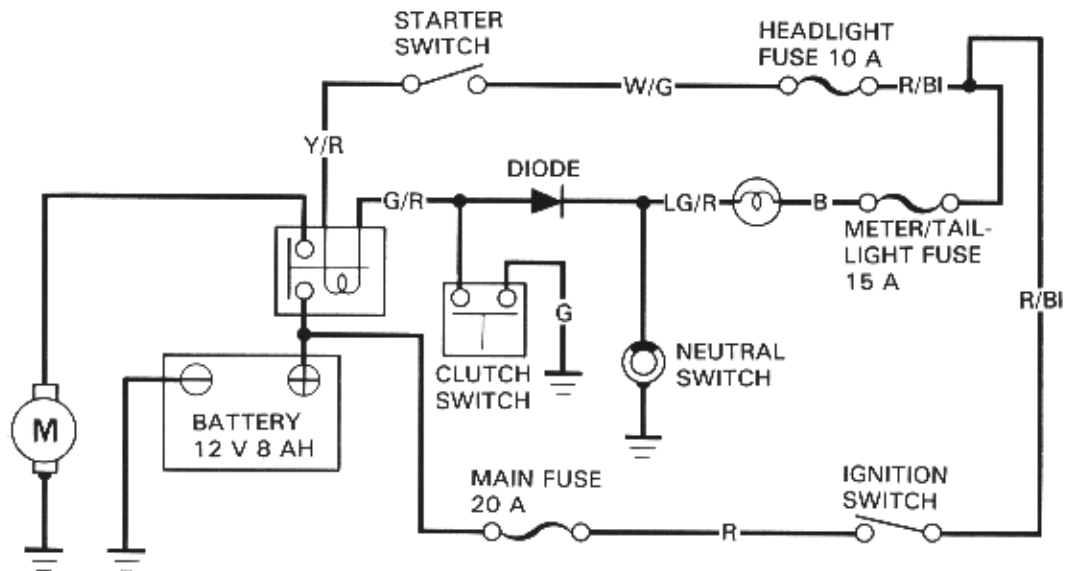
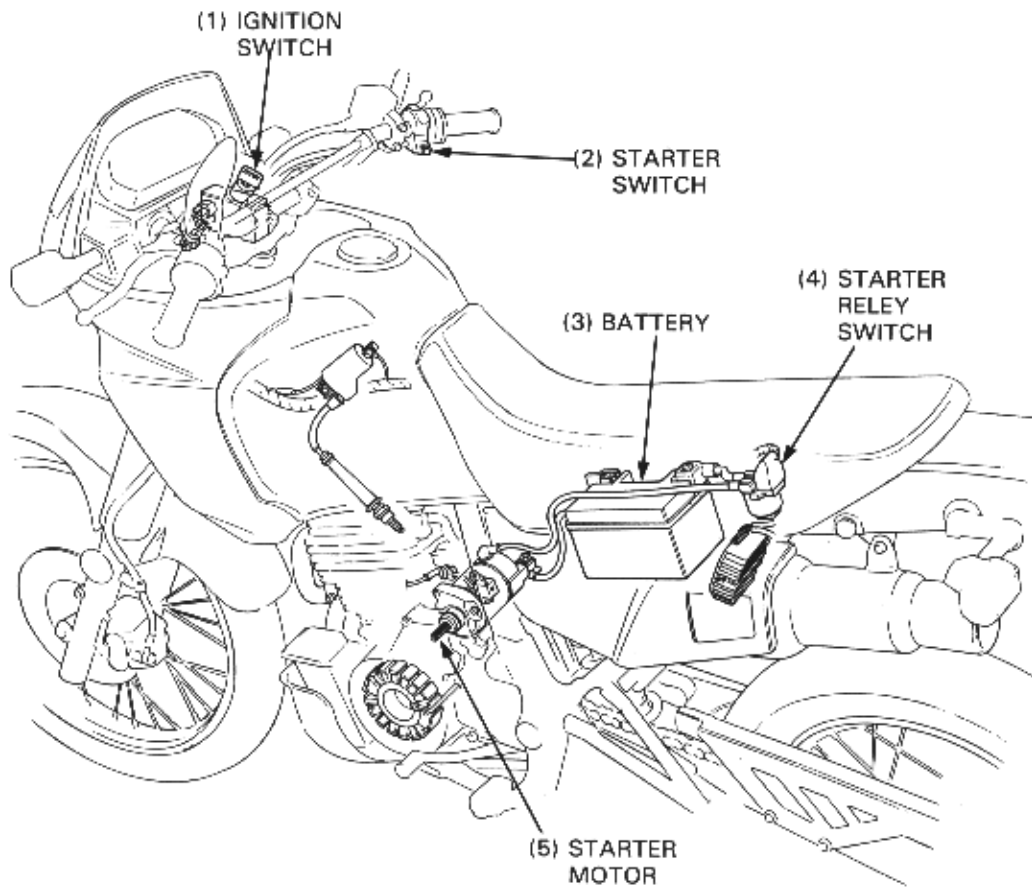

|    |       |        |    |       |             |
|----|-------|--------|----|-------|-------------|
| Bl | ..... | BLACK  | Br | ..... | BROWN       |
| Y  | ..... | YELLOW | O  | ..... | ORANGE      |
| Bu | ..... | BLUE   | Lb | ..... | LIGHT BLUE  |
| G  | ..... | GREEN  | Lg | ..... | LIGHT GREEN |
| R  | ..... | RED    | P  | ..... | PINK        |
| W  | ..... | WHITE  | Gr | ..... | GRAY        |

# 18. ELECTRIC STARTER SYSTEM

|                     |      |                      |      |
|---------------------|------|----------------------|------|
| SYSTEM DIAGRAM      | 18-0 | STARTER MOTOR        | 18-3 |
| SERVICE INFORMATION | 18-1 | STARTER RELAY SWITCH | 18-7 |
| TROUBLESHOOTING     | 18-2 | CLUTCH DIODE         | 18-8 |

## SERVICE INFORMATION

### GENERAL

- The starter motor can be removed with the engine in the frame.

### SPECIFICATIONS

mm (in)

| ITEM                       | STANDARD              | SERVICE LIMIT |
|----------------------------|-----------------------|---------------|
| Starter motor brush length | 12.0–13.0 (0.47–0.51) | 6.5 (0.26)    |

**TROUBLESHOOTING**

**NOTE**

- The starter motor could turn when the transmission is in neutral or the clutch disengaged.
- Check the following items before troubleshooting the system.
  - Main (20A) and sub (10A and 15A) fuses for burn.
  - Battery and starter motor cables for loose connection.
  - Battery discharged.

**Starter motor do not turn**

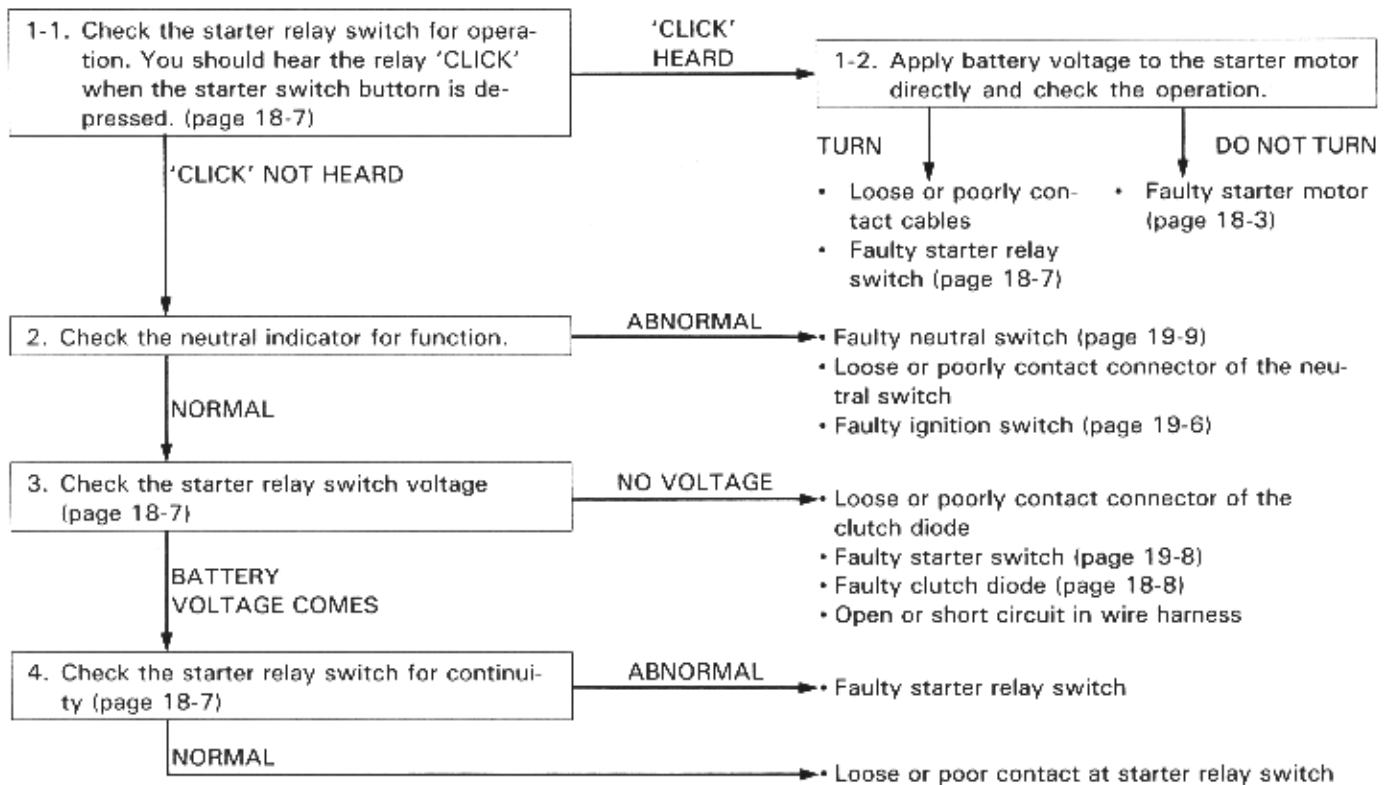

**Starter motor turns engine slowly**

- Low specific gravity
- Excessive resistance in circuit (Section 9)
- Binding in starter motor shaft (Section 9)

**Starter motor turns, but engine does not turn**

- Faulty starter clutch (Section 9)
- Faulty starter motor gears (Section 9)
- Faulty starter motor or idle gear (Section 9)

**Starter motor and engine turns, but engine does not start**

- Faulty ignition system
- Engine problems (Section 20)
  - Low compression
  - Fouled spark plug

## STARTER MOTOR

### REMOVAL

#### ⚠ WARNING

- *With the ignition switch OFF, remove the negative cable at the battery before servicing the starter motor.*

Remove the clutch cable holder from the starter motor.

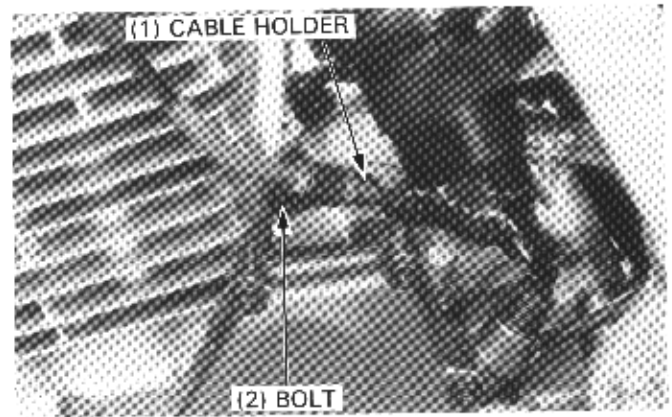

Disconnect the starter motor cable.  
Remove the motor mounting bolts, starter motor, set rubber and motor stay.

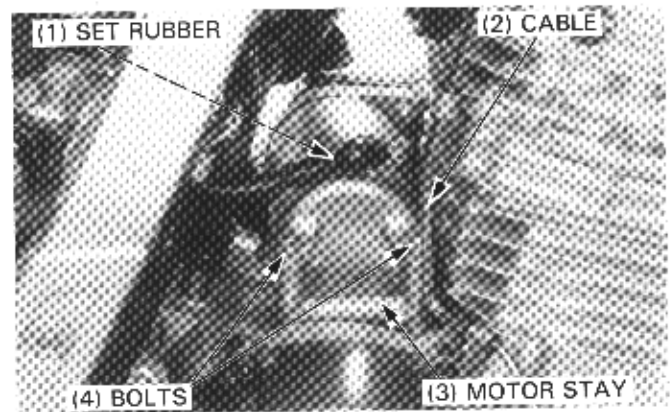

### DISASSEMBLY

Remove the following components:

- motor case bolts
- front cover and rear cover
- armature

#### NOTE

- Record the location and number of shims.

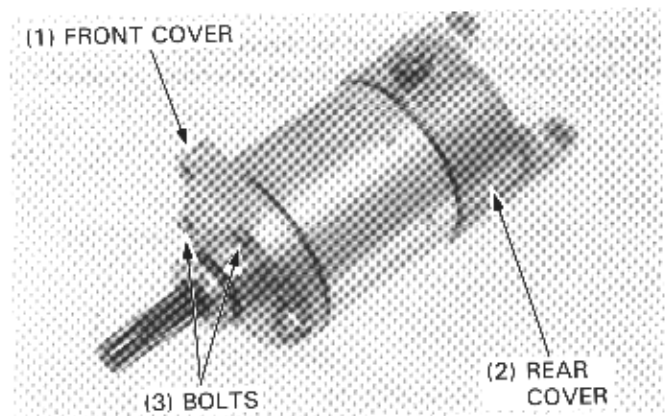

### INSPECTION

Check for continuity from the cable terminal to each brush.

**CONTINUITY: NORMAL**

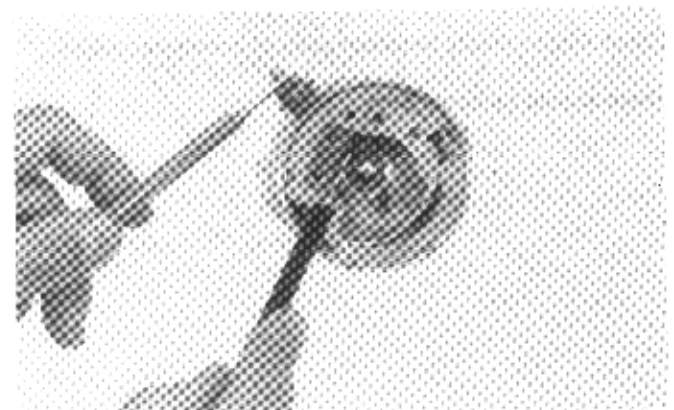

## ELECTRIC STARTER SYSTEM

Check for continuity from the cable terminal to the front cover.

**NO CONTINUITY: NORMAL**

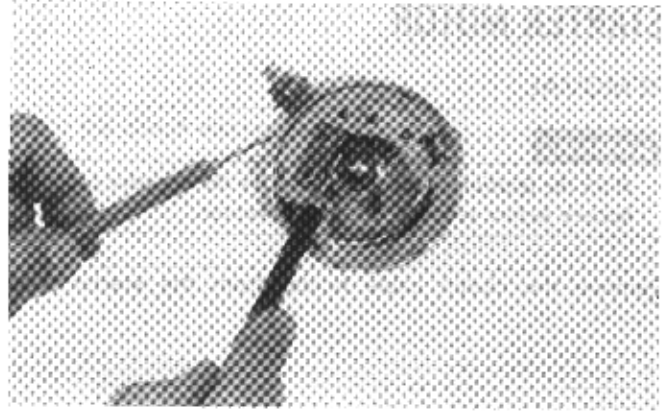

Measure each brush length.

**SERVICE LIMIT: 6.5 mm (0.26 in)**

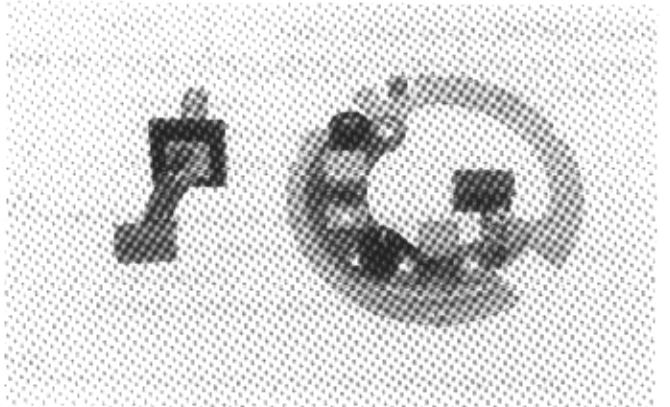

Inspect the commutator bars for discoloration.  
The bars discolored in pairs indicate grounded armature coils.

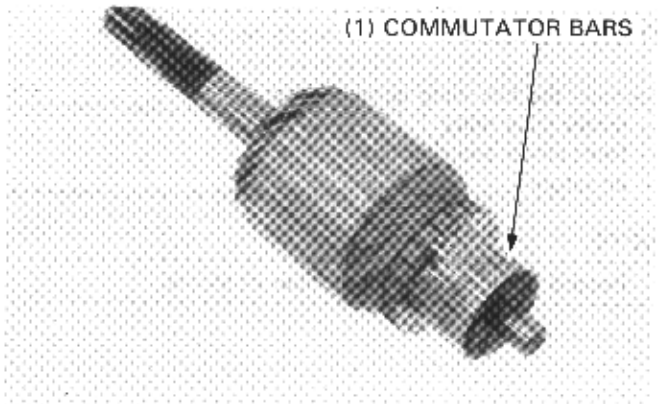

Check for continuity between pairs of commutator bars.

There should be continuity.

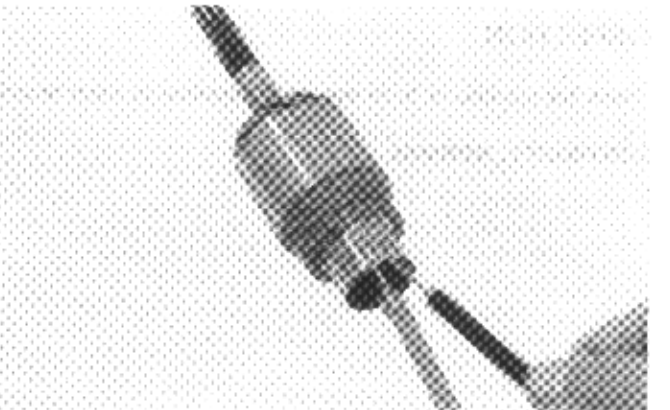

Check for continuity between individual commutator bars and the armature shaft.

There should be no continuity.

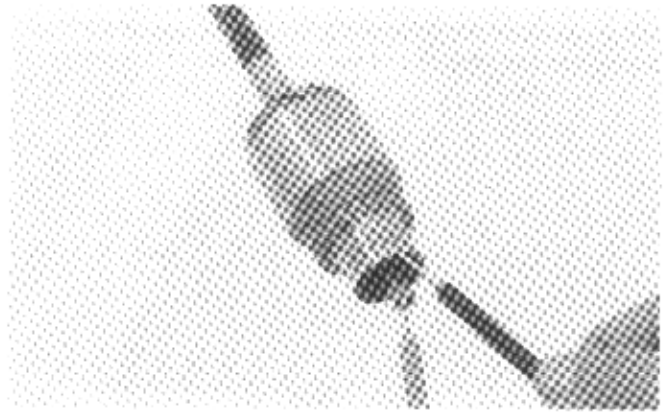

Check the dust seal of the front cover for wear or fatigue.

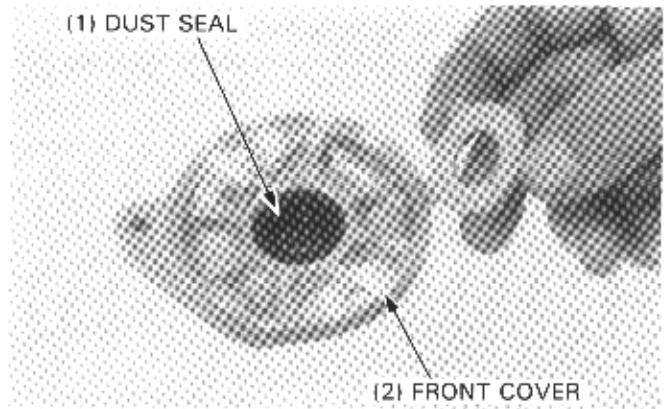

ASSEMBLY

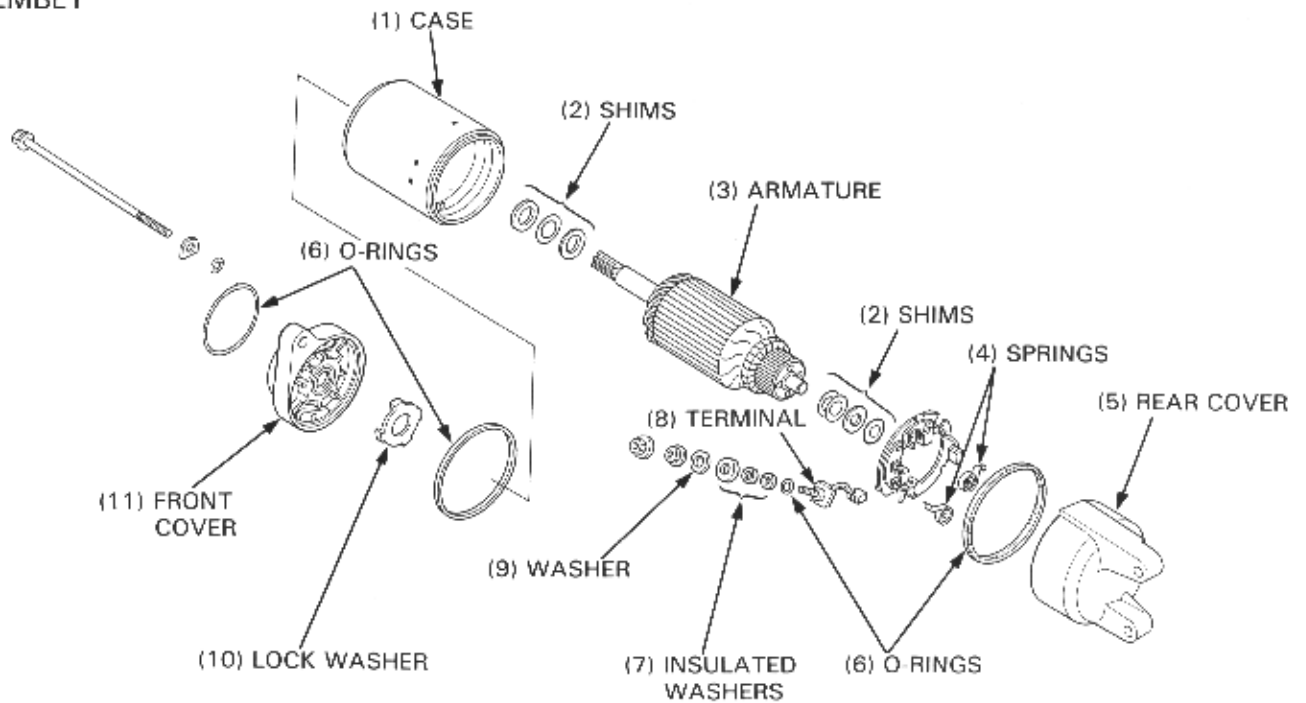

## ELECTRIC STARTER SYSTEM

Install the brush holder onto the rear cover, aligning the tang of the holder with the slot of the rear cover.

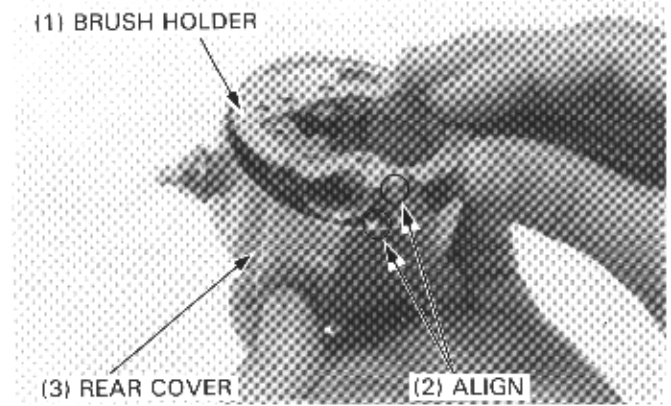

Install the armature into the motor case.  
Install the shims in the same location and number when disassembled.  
Install the O-rings on the motor case.  
Install the rear cover, aligning its slot with the tang of the brush holder.

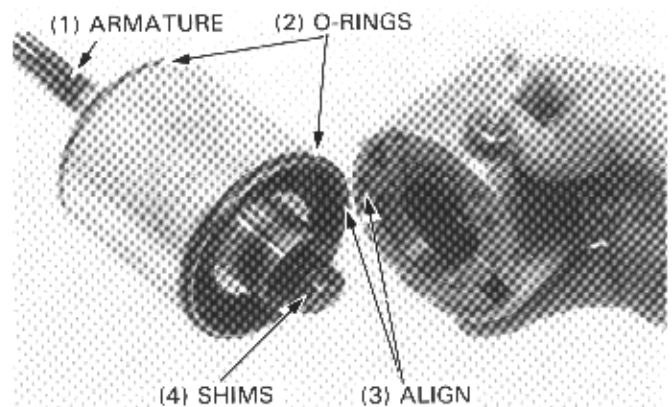

Install the shims in the same location and number when disassembled.

Install the lock washer, aligning its tabs with the slots of the front cover.  
Apply grease to the dust seal.  
Install the front cover.

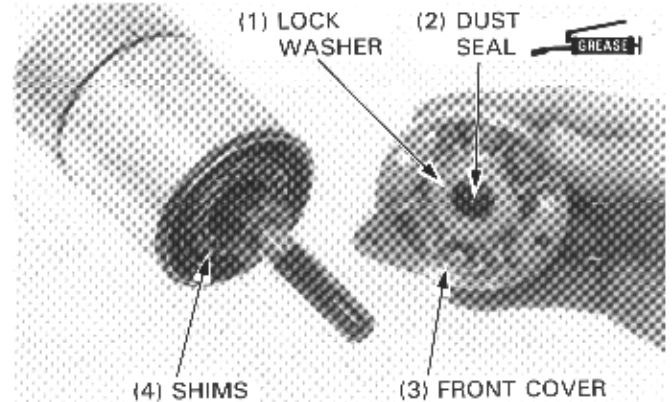

Align the index marks of the front cover, case and rear cover as shown.  
Tighten the motor case bolts securely with the O-rings and washers.

Apply oil to the O-ring and install it into the front case groove.

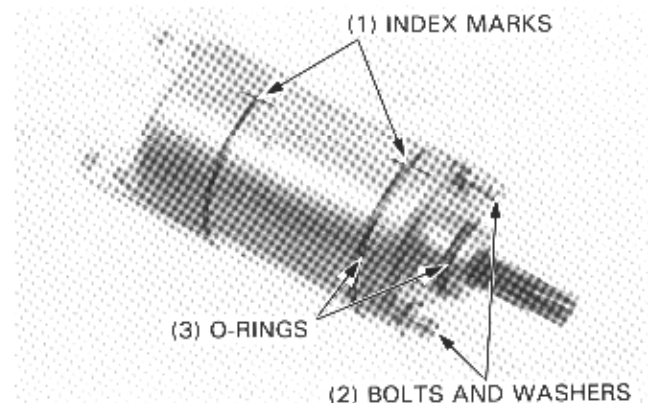

## INSTALLATION

Set the motor stay and set rubber onto the engine. Install the starter motor on the rubber and stay, and tighten the mounting bolts.

### NOTE

- Install the ground cable with one mounting bolt as shown.

Connect the motor cable to the motor terminal.  
Put the rubber cap on the terminal.  
Connect the battery negative cable.

Install the clutch cable holder, aligning its hole with the boss on the starter motor, and secure with the bolt.

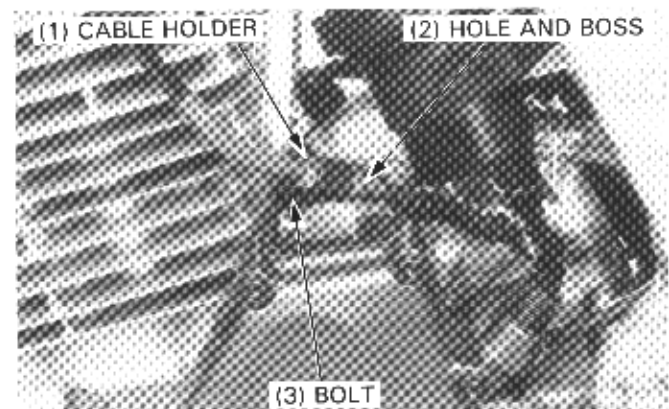
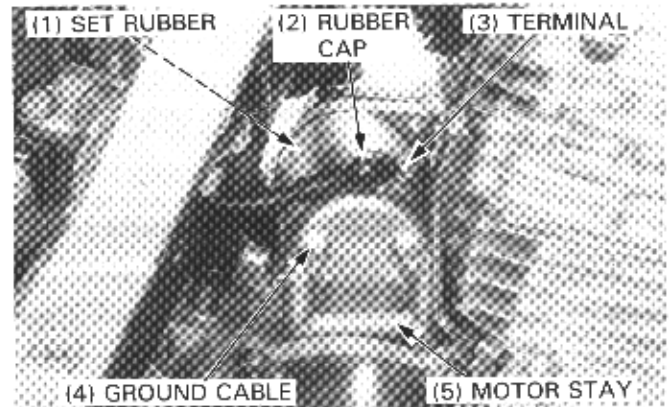

## STARTER RELAY SWITCH

### OPERATION INSPECTION

Remove the rear fender (page 15-5).  
Depress the starter switch button with the ignition ON.  
The coil is normal if the starter relay switch clicks.

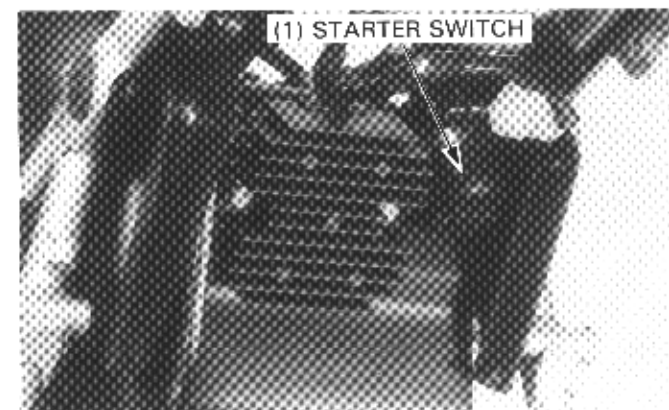

### VOLTAGE INSPECTION

If the switch 'CLICK' is not heard, measure the voltage between the yellow/red (+) and green/red (-) wires of the relay connector. The battery voltage should appear when the starter switch button is depressed with the ignition switch ON and neutral position.

Perform the following inspection if the battery voltage appeared between the yellow/red and green/red wires.

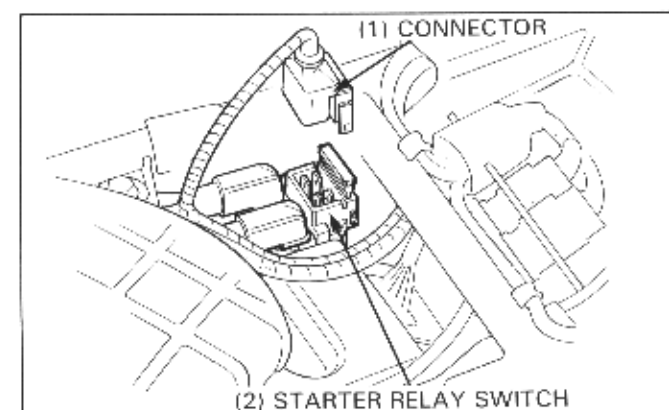



## ELECTRIC STARTER SYSTEM

### CONTINUITY INSPECTION

Remove the starter relay switch.

Connect an ohmmeter to the starter relay switch large terminals.

Connect a fully charged 12 V battery positive wire to the starter relay switch Yellow/Red wire terminal and battery negative wire to the Green/Red wire terminal.

Check for continuity between the starter relay switch terminals.

There should be continuity while the 12 V battery is connected to the starter relay switch terminals and should be no continuity when the battery is disconnected.

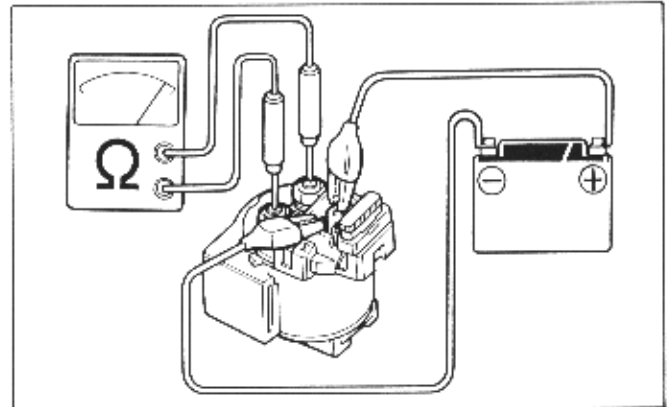

### CLUTCH DIODE

#### NOTE

- Clutch diode is located under the seat.

#### INSPECTION

Check for continuity with an ohmmeter.

**NORMAL DIRECTION: CONTINUITY**  
**REVERSE DIRECTION: NO CONTINUITY**

'88 SHOWN:

